

PART I : PHYSICS

SECTION I : Single Correct Answer Type

This section contains **8 multiple choice questions**. Each question has four choices (A), (B), (C) and (D) out of which **ONLY ONE is correct**.

1. A loop carrying current I lies in the x - y plane as shown in the figure. The unit vector \hat{k} is coming out of the plane of the paper. The magnetic moment of the current loop is

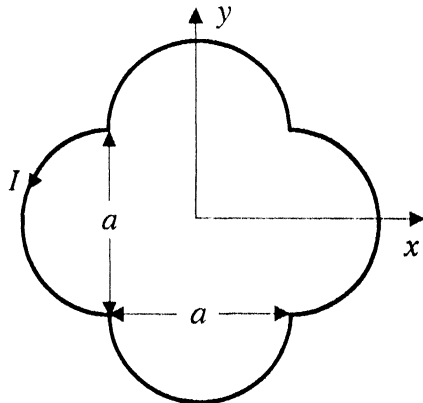

- (A) $a^2 I \hat{k}$ (B) $\left(\frac{\pi}{2} + 1\right) a^2 I \hat{k}$ (C) $-\left(\frac{\pi}{2} + 1\right) a^2 I \hat{k}$ (D) $(2\pi + 1) a^2 I \hat{k}$

ANSWER : B

2. An infinitely long hollow conducting cylinder with inner radius $R/2$ and outer radius R carries a uniform current density along its length. The magnitude of the magnetic field, $|\vec{B}|$ as a function of the radial distance r from the axis is best represented by

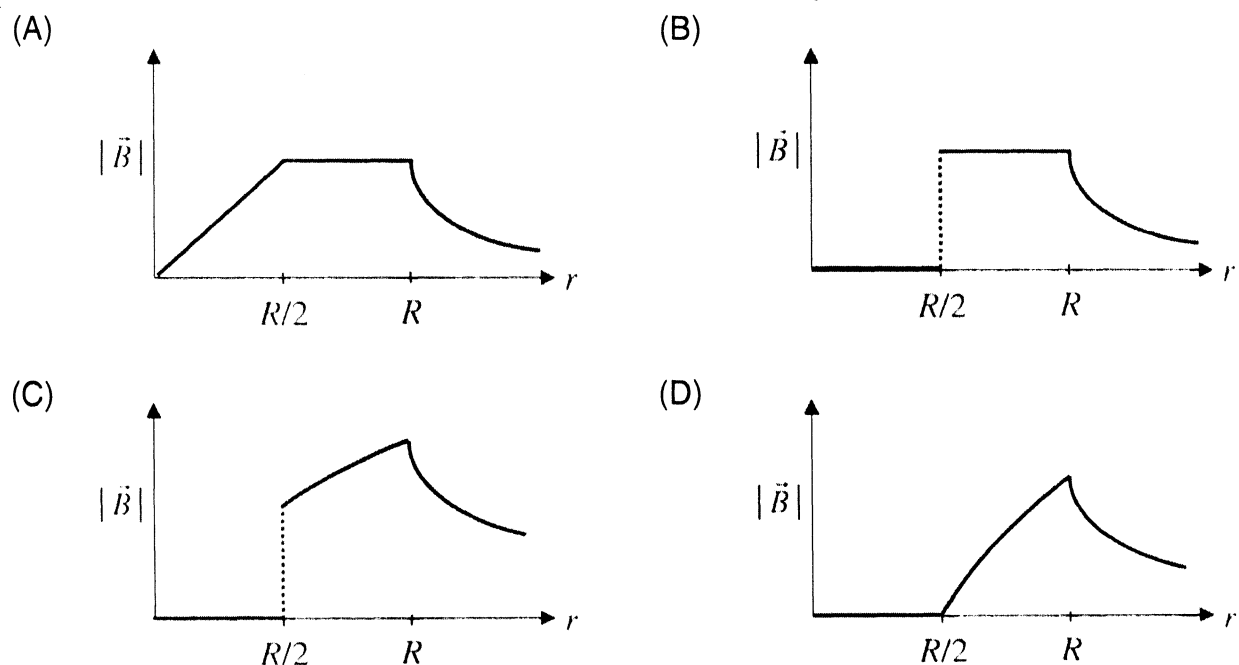

ANSWER : D

3. A thin uniform cylindrical shell, closed at both ends, is partially filled with water. It is floating vertically in water in half-submerged state. If ρ_c is the relative density of the material of the shell with respect to water, then the correct statement is that the shell is
- (A) more than half-filled if ρ_c is less than 0.5.
 (B) more than half-filled if ρ_c is more than 1.0.
 (C) half-filled if ρ_c is more than 0.5.
 (D) less than half-filled if ρ_c is less than 0.5.

ANSWER : A

4. In the given circuit, a charge of $+80 \mu\text{C}$ is given to the upper plate of the $4 \mu\text{F}$ capacitor. Then in the steady state, the charge on the upper plate of the $3 \mu\text{F}$ capacitor is

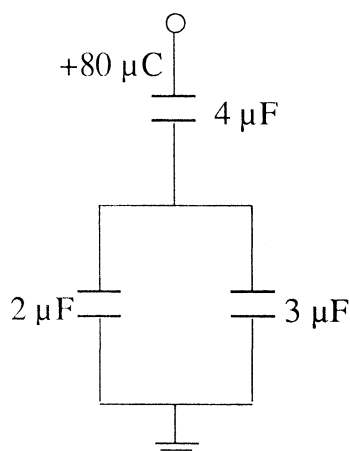

- (A) $+32 \mu\text{C}$ (B) $+40 \mu\text{C}$ (C) $+48 \mu\text{C}$ (D) $+80 \mu\text{C}$

ANSWER : C

5. Two moles of ideal helium gas are in a rubber balloon at 30°C . The balloon is fully expandable and can be assumed to require no energy in its expansion. The temperature of the gas in the balloon is slowly changed to 35°C . The amount of heat required in raising the temperature is nearly (take $R = 8.31 \text{ J/mol.K}$)
- (A) 62 J (B) 104 J (C) 124 J (D) 208 J

ANSWER : D

6. Consider a disc rotating in the horizontal plane with a constant angular speed ω about its centre O . The disc has a shaded region on one side of the diameter and an unshaded region on the other side as shown in the figure. When the disc is in the orientation as shown, two pebbles P and Q are simultaneously projected at an angle towards R . The velocity of projection is in the y - z plane and is same for both pebbles with respect to the disc. Assume that (i) they land back on the disc before the disc has completed $\frac{1}{8}$ rotation, (ii) their range is less than half the disc radius, and (iii) ω remains constant throughout. Then

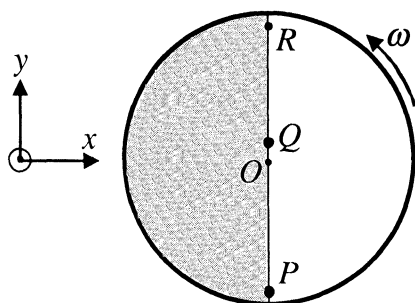

- (A) P lands in the shaded region and Q in the unshaded region.
 (B) P lands in the unshaded region and Q in the shaded region.
 (C) Both P and Q land in the unshaded region.
 (D) Both P and Q land in the shaded region.

ANSWER : C or D

7. A student is performing the experiment of Resonance Column. The diameter of the column tube is 4 cm. The frequency of the tuning fork is 512 Hz. The air temperature is 38°C in which the speed of sound is 336 m/s. The zero of the meter scale coincides with the top end of the Resonance Column tube. When the first resonance occurs, the reading of the water level in the column is
- (A) 14.0 cm (B) 15.2 cm (C) 16.4 cm (D) 17.6 cm

ANSWER : B

8. Two identical discs of same radius R are rotating about their axes in opposite directions with the same constant angular speed ω . The discs are in the same horizontal plane. At time $t = 0$, the points P and Q are facing each other as shown in the figure. The relative speed between the two points P and Q is v_r . In one time period (T) of rotation of the discs, v_r as a function of time is best represented by

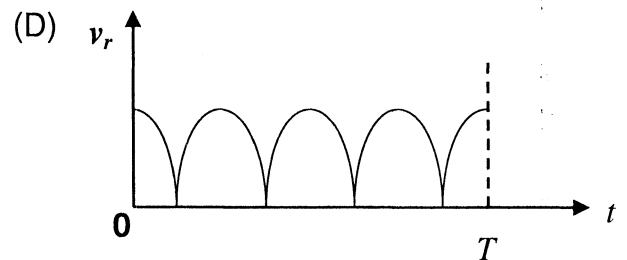
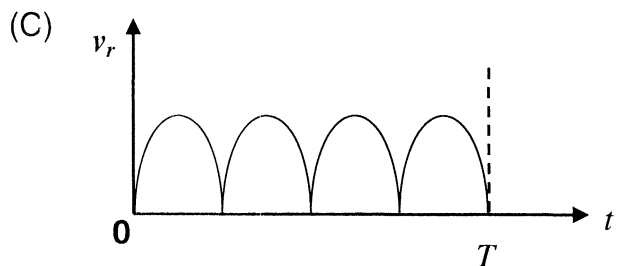
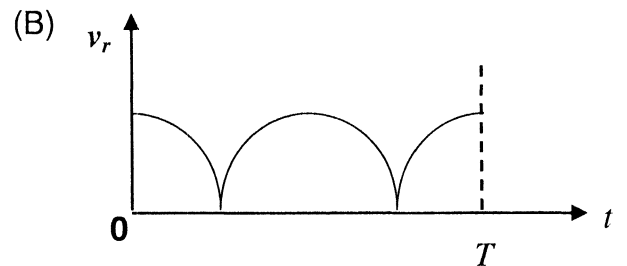
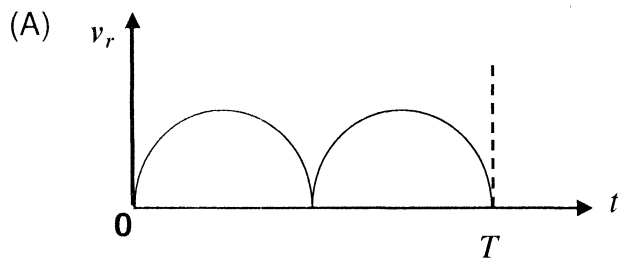
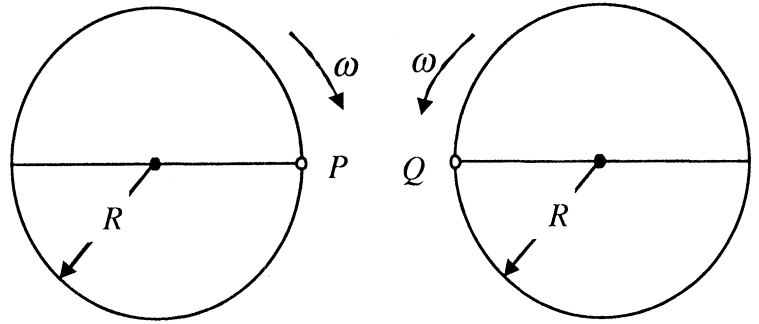

ANSWER : A

SECTION II : Paragraph Type

This section contains **6 multiple choice questions** relating to three paragraphs with **two questions on each paragraph**. Each question has four choices (A), (B), (C) and (D) out of which **ONLY ONE is correct**.

Paragraph for Questions 9 and 10

Most materials have the refractive index, $n > 1$. So, when a light ray from air enters a naturally occurring material, then by Snell's law, $\frac{\sin \theta_1}{\sin \theta_2} = \frac{n_2}{n_1}$, it is understood that the refracted ray bends towards the normal. But it never emerges on the same side of the normal as the incident ray. According to electromagnetism, the refractive index of the medium is given by the relation, $n = \left(\frac{c}{v}\right) = \pm\sqrt{\epsilon_r \mu_r}$, where c is the speed of electromagnetic waves in vacuum, v its speed in the medium, ϵ_r and μ_r are the relative permittivity and permeability of the medium respectively.

In normal materials, both ϵ_r and μ_r are positive, implying positive n for the medium. When both ϵ_r and μ_r are negative, one must choose the negative root of n . Such negative refractive index materials can now be artificially prepared and are called meta-materials. They exhibit significantly different optical behavior, without violating any physical laws. Since n is negative, it results in a change in the direction of propagation of the refracted light. However, similar to normal materials, the frequency of light remains unchanged upon refraction even in meta-materials.

9. For light incident from air on a meta-material, the appropriate ray diagram is

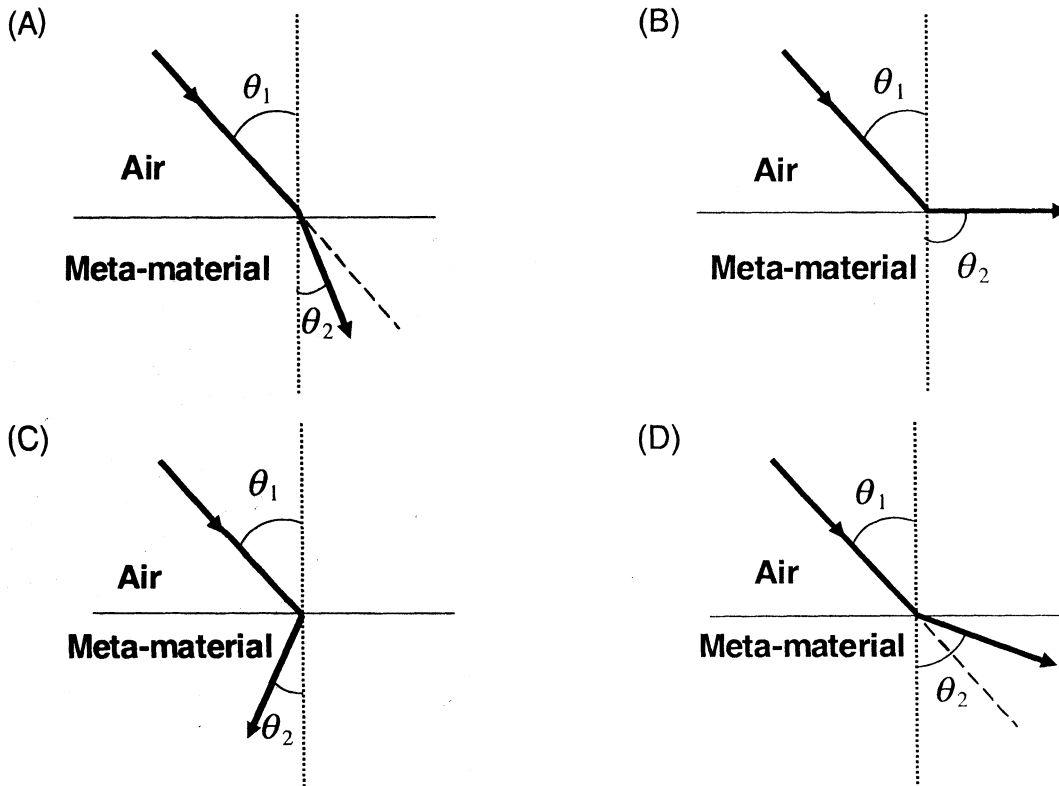

ANSWER : C

10. Choose the correct statement.

(A) The speed of light in the meta-material is $v = c|n|$

(B) The speed of light in the meta-material is $v = \frac{c}{|n|}$

(C) The speed of light in the meta-material is $v = c$.

(D) The wavelength of the light in the meta-material (λ_m) is given by $\lambda_m = \lambda_{air}|n|$, where λ_{air} is the wavelength of the light in air.

ANSWER : B

Paragraph for Questions 11 and 12

The β -decay process, discovered around 1900, is basically the decay of a neutron (n). In the laboratory, a proton (p) and an electron (e^-) are observed as the decay products of the neutron. Therefore, considering the decay of a neutron as a two-body decay process, it was predicted theoretically that the kinetic energy of the electron should be a constant. But experimentally, it was observed that the electron kinetic energy has a continuous spectrum. Considering a three-body decay process, i.e. $n \rightarrow p + e^- + \bar{\nu}_e$, around 1930, Pauli explained the observed electron energy spectrum. Assuming the anti-neutrino ($\bar{\nu}_e$) to be massless and possessing negligible energy, and the neutron to be at rest, momentum and energy conservation principles are applied. From this calculation, the maximum kinetic energy of the electron is 0.8×10^6 eV. The kinetic energy carried by the proton is only the recoil energy.

11. What is the maximum energy of the anti-neutrino?

- (A) Zero. (B) Much less than 0.8×10^6 eV.
(C) Nearly 0.8×10^6 eV. (D) Much larger than 0.8×10^6 eV.

ANSWER : C

12. If the anti-neutrino had a mass of $3 \text{ eV}/c^2$ (where c is the speed of light) instead of zero mass, what should be the range of the kinetic energy, K , of the electron?

- (A) $0 \leq K \leq 0.8 \times 10^6$ eV (B) $3.0 \text{ eV} \leq K \leq 0.8 \times 10^6$ eV
(C) $3.0 \text{ eV} \leq K < 0.8 \times 10^6$ eV (D) $0 \leq K < 0.8 \times 10^6$ eV

ANSWER : D

Paragraph for Questions 13 and 14

The general motion of a rigid body can be considered to be a combination of (i) a motion of its centre of mass about an axis, and (ii) its motion about an instantaneous axis passing through the centre of mass. These axes need not be stationary. Consider, for example, a thin uniform disc welded (rigidly fixed) horizontally at its rim to a massless stick, as shown in the figure. When the disc–stick system is rotated about the origin on a horizontal frictionless plane with angular speed ω , the motion at any instant can be taken as a combination of (i) a rotation of the centre of mass of the disc about the z -axis, and (ii) a rotation of the disc through an instantaneous vertical axis passing through its centre of mass (as is seen from the changed orientation of points P and Q). Both these motions have the same angular speed ω in this case.

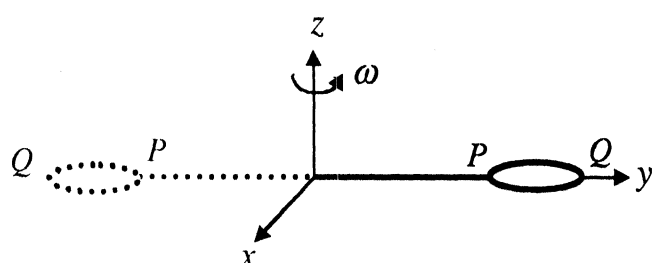

Now consider two similar systems as shown in the figure: Case (a) the disc with its face vertical and parallel to x - z plane; Case (b) the disc with its face making an angle of 45° with x - y plane and its horizontal diameter parallel to x -axis. In both the cases, the disc is welded at point P , and the systems are rotated with constant angular speed ω about the z -axis.

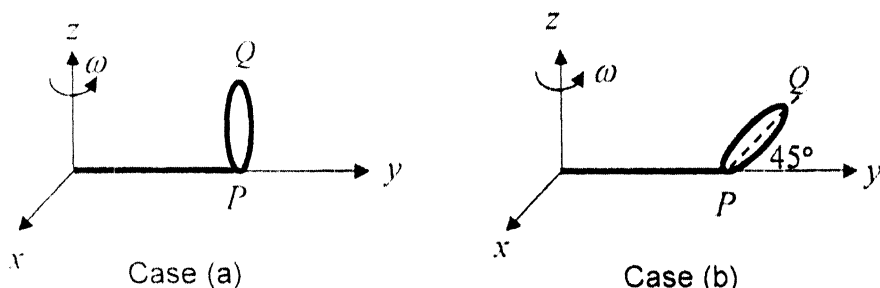

13. Which of the following statements about the instantaneous axis (passing through the centre of mass) is correct?
- (A) It is vertical for both the cases (a) and (b).
 - (B) It is vertical for case (a); and is at 45° to the x - z plane and lies in the plane of the disc for case (b).
 - (C) It is horizontal for case (a); and is at 45° to the x - z plane and is normal to the plane of the disc for case (b).
 - (D) It is vertical for case (a); and is at 45° to the x - z plane and is normal to the plane of the disc for case (b).

ANSWER : A

14. Which of the following statements regarding the angular speed about the instantaneous axis (passing through the centre of mass) is correct?
- (A) It is $\sqrt{2}\omega$ for both the cases.
 - (B) It is ω for case (a); and $\frac{\omega}{\sqrt{2}}$ for case (b).
 - (C) It is ω for case (a); and $\sqrt{2}\omega$ for case (b).
 - (D) It is ω for both the cases.

ANSWER : D

SECTION III : Multiple Correct Answer(s) Type

This section contains **6 multiple choice questions**. Each question has four choices (A), (B), (C) and (D) out of which **ONE or MORE are correct**.

15. In the given circuit, the AC source has $\omega = 100 \text{ rad/s}$. Considering the inductor and capacitor to be ideal, the correct choice(s) is(are)

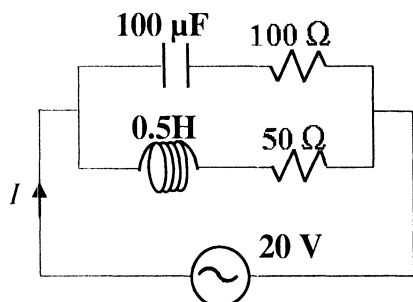

- (A) The current through the circuit, I is 0.3 A.
 (B) The current through the circuit, I is $0.3\sqrt{2}$ A.
 (C) The voltage across 100Ω resistor = $10\sqrt{2}$ V.
 (D) The voltage across 50Ω resistor = 10 V.

ANSWER : C or AC

16. A current carrying infinitely long wire is kept along the diameter of a circular wire loop, without touching it. The correct statement(s) is(are)
- (A) The emf induced in the loop is zero if the current is constant.
 (B) The emf induced in the loop is finite if the current is constant.
 (C) The emf induced in the loop is zero if the current decreases at a steady rate.
 (D) The emf induced in the loop is finite if the current decreases at a steady rate.

ANSWER : AC

17. Six point charges are kept at the vertices of a regular hexagon of side L and centre O , as shown in the figure. Given that $K = \frac{1}{4\pi\epsilon_0} \frac{q}{L^2}$, which of the following statement(s) is(are) correct ?

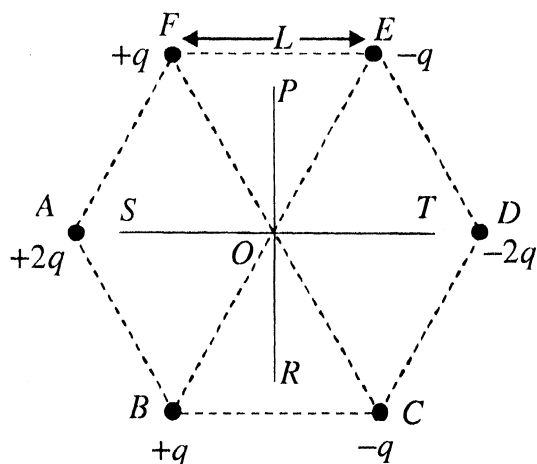

- (A) The electric field at O is $6K$ along OD .
 (B) The potential at O is zero.
 (C) The potential at all points on the line PR is same.
 (D) The potential at all points on the line ST is same.

ANSWER : ABC

18. Two solid cylinders P and Q of same mass and same radius start rolling down a fixed inclined plane from the same height at the same time. Cylinder P has most of its mass concentrated near its surface, while Q has most of its mass concentrated near the axis. Which statement(s) is(are) correct ?
- (A) Both cylinders P and Q reach the ground at the same time.
 (B) Cylinder P has larger linear acceleration than cylinder Q .
 (C) Both cylinders reach the ground with same translational kinetic energy.
 (D) Cylinder Q reaches the ground with larger angular speed.

ANSWER : D

19. Two spherical planets P and Q have the same uniform density ρ , masses M_P and M_Q , and surface areas A and $4A$, respectively. A spherical planet R also has uniform density ρ and its mass is $(M_P + M_Q)$. The escape velocities from the planets P , Q and R , are V_P , V_Q and V_R , respectively. Then

- (A) $V_Q > V_R > V_P$ (B) $V_R > V_Q > V_P$ (C) $V_R/V_P = 3$ (D) $V_P/V_Q = \frac{1}{2}$

ANSWER : BD

20. The figure shows a system consisting of (i) a ring of outer radius $3R$ rolling clockwise without slipping on a horizontal surface with angular speed ω and (ii) an inner disc of radius $2R$ rotating anti-clockwise with angular speed $\omega/2$. The ring and disc are separated by frictionless ball bearings. The system is in the x - z plane. The point P on the inner disc is at a distance R from the origin, where OP makes an angle of 30° with the horizontal. Then with respect to the horizontal surface,

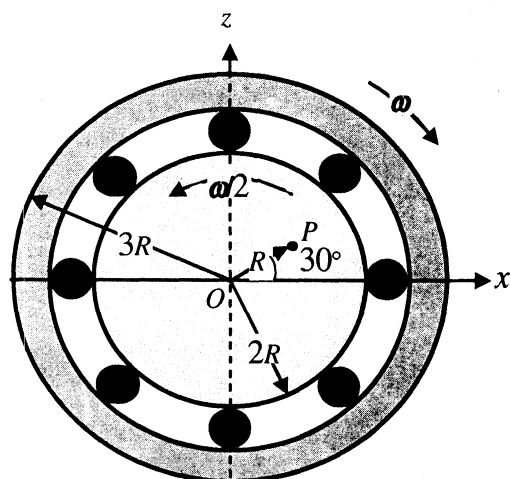

- (A) the point O has a linear velocity $3R\omega\hat{i}$.
- (B) the point P has a linear velocity $\frac{11}{4}R\omega\hat{i} + \frac{\sqrt{3}}{4}R\omega\hat{k}$.
- (C) the point P has a linear velocity $\frac{13}{4}R\omega\hat{i} - \frac{\sqrt{3}}{4}R\omega\hat{k}$.
- (D) the point P has a linear velocity $\left(3 - \frac{\sqrt{3}}{4}\right)R\omega\hat{i} + \frac{1}{4}R\omega\hat{k}$.

ANSWER : AB

PART II : CHEMISTRY

SECTION I : Single Correct Answer Type

This section contains **8 multiple choice questions**. Each question has four choices (A), (B), (C) and (D) out of which **ONLY ONE is correct**.

21. $\text{NiCl}_2\{\text{P}(\text{C}_2\text{H}_5)_2(\text{C}_6\text{H}_5)\}_2$ exhibits temperature dependent magnetic behaviour (paramagnetic / diamagnetic). The coordination geometries of Ni^{2+} in the paramagnetic and diamagnetic states are respectively
- (A) tetrahedral and tetrahedral (B) square planar and square planar
(C) tetrahedral and square planar (D) square planar and tetrahedral

ANSWER : C

22. In the cyanide extraction process of silver from argentite ore, the oxidizing and reducing agents used are
- (A) O_2 and CO respectively. (B) O_2 and Zn dust respectively.
(C) HNO_3 and Zn dust respectively. (D) HNO_3 and CO respectively.

ANSWER : B

23. The reaction of white phosphorus with aqueous NaOH gives phosphine along with another phosphorus containing compound. The reaction type; the oxidation states of phosphorus in phosphine and the other product are respectively
- (A) redox reaction; -3 and -5
(B) redox reaction; $+3$ and $+5$
(C) disproportionation reaction; -3 and $+5$
(D) disproportionation reaction; -3 and $+3$

Zero Marks to all

24. The shape of XeO_2F_2 molecule is
 (A) trigonal bipyramidal (B) square planar
 (C) tetrahedral (D) see-saw

ANSWER : D

25. For a dilute solution containing 2.5 g of a non-volatile non-electrolyte solute in 100 g of water, the elevation in boiling point at 1 atm pressure is 2°C . Assuming concentration of solute is much lower than the concentration of solvent, the vapour pressure (mm of Hg) of the solution is (take $K_b = 0.76 \text{ K kg mol}^{-1}$)
 (A) 724 (B) 740 (C) 736 (D) 718

ANSWER : A

26. The compound that undergoes decarboxylation most readily under mild condition is

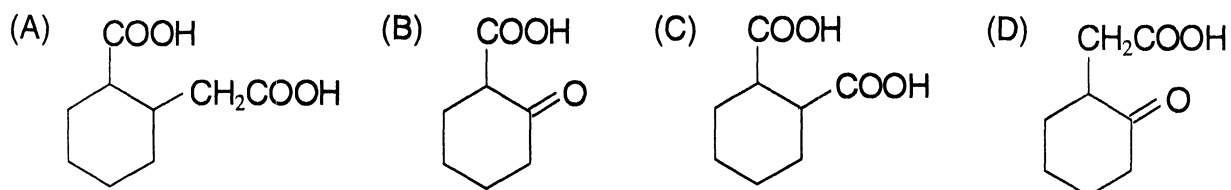

ANSWER : B

27. Using the data provided, calculate the multiple bond energy (kJ mol^{-1}) of a $\text{C}\equiv\text{C}$ bond in C_2H_2 . That energy is (take the bond energy of a C-H bond as 350 kJ mol^{-1} .)

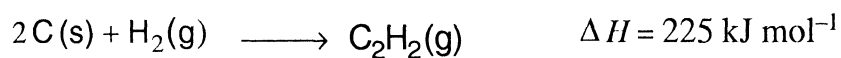

- (A) 1165 (B) 837 (C) 865 (D) 815

ANSWER : D

28. The major product **H** of the given reaction sequence is

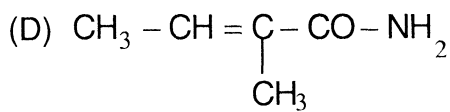
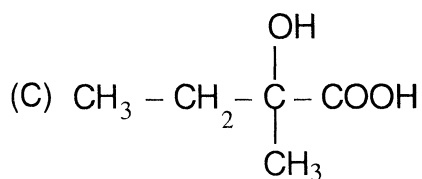
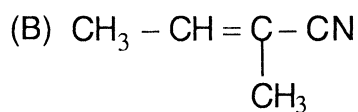
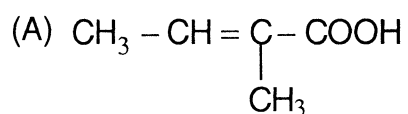
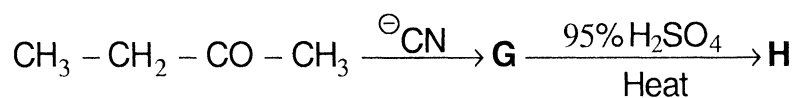

ANSWER : A

SECTION II : Paragraph Type

This section contains **6 multiple choice questions** relating to three paragraphs with **two questions on each paragraph**. Each question has four choices (A), (B), (C) and (D) out of which **ONLY ONE is correct**.

Paragraph for Questions 29 and 30

Bleaching powder and bleach solution are produced on a large scale and used in several household products. The effectiveness of bleach solution is often measured by iodometry.

29. Bleaching powder contains a salt of an oxoacid as one of its components. The anhydride of that oxoacid is
- (A) Cl_2O (B) Cl_2O_7 (C) ClO_2 (D) Cl_2O_6

ANSWER : A

30. 25 mL of household bleach solution was mixed with 30 mL of 0.50 M KI and 10 mL of 4 N acetic acid. In the titration of the liberated iodine, 48 mL of 0.25 N $\text{Na}_2\text{S}_2\text{O}_3$ was used to reach the end point. The molarity of the household bleach solution is
- (A) 0.48 M (B) 0.96 M (C) 0.24 M (D) 0.024 M

ANSWER : C

Paragraph for Questions 31 and 32

The electrochemical cell shown below is a concentration cell.

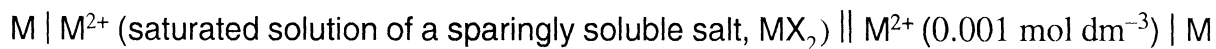

The emf of the cell depends on the difference in concentrations of M^{2+} ions at the two electrodes.

The emf of the cell at 298 K is 0.059 V.

31. The solubility product (K_{sp} ; $\text{mol}^3 \text{ dm}^{-9}$) of MX_2 at 298 K based on the information available for the given concentration cell is (take $2.303 \times R \times 298/F = 0.059 \text{ V}$)

- (A) 1×10^{-15} (B) 4×10^{-15} (C) 1×10^{-12} (D) 4×10^{-12}

ANSWER : B

32. The value of ΔG (kJ mol^{-1}) for the given cell is (take $1F = 96500 \text{ C mol}^{-1}$)

- (A) -5.7 (B) 5.7 (C) 11.4 (D) -11.4

ANSWER : D

Paragraph for Questions 33 and 34

In the following reaction sequence, the compound **J** is an intermediate.

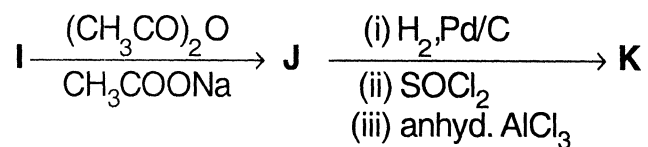

J ($\text{C}_9\text{H}_8\text{O}_2$) gives effervescence on treatment with NaHCO_3 and a positive Baeyer's test.

33. The compound **I** is

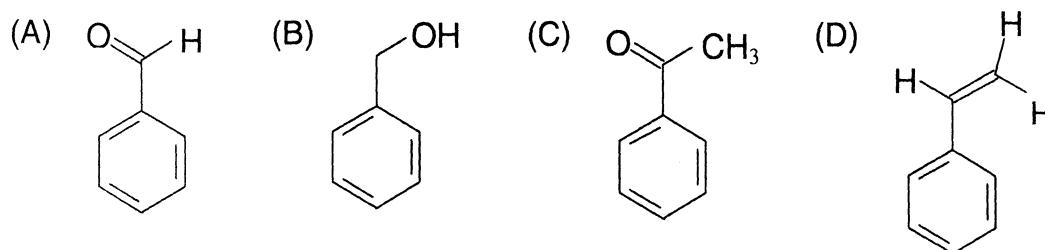

ANSWER : A

34. The compound **K** is

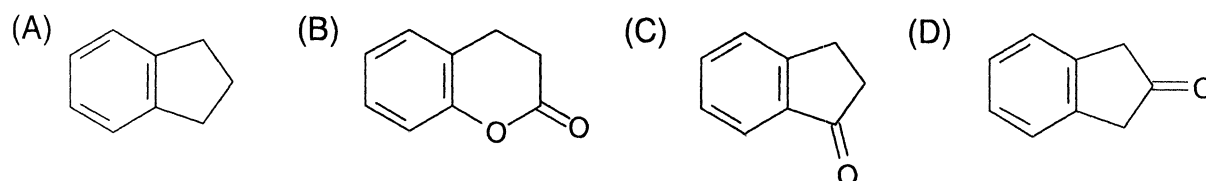

ANSWER : C

SECTION III : Multiple Correct Answer(s) Type

This section contains 6 multiple choice questions. Each question has four choices (A), (B), (C) and (D) out of which **ONE or MORE** are correct.

35. The reversible expansion of an ideal gas under adiabatic and isothermal conditions is shown in the figure. Which of the following statement(s) is (are) correct?

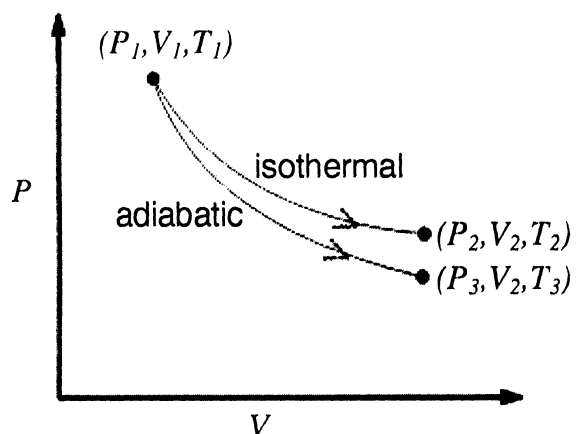

(A) $T_1 = T_2$

(B) $T_3 > T_1$

(C) $w_{\text{isothermal}} > w_{\text{adiabatic}}$

(D) $\Delta U_{\text{isothermal}} > \Delta U_{\text{adiabatic}}$

ANSWER : ACD or AD

36. The given graphs / data I, II, III and IV represent general trends observed for different physisorption and chemisorption processes under mild conditions of temperature and pressure. Which of the following choice(s) about I, II, III and IV is (are) correct?

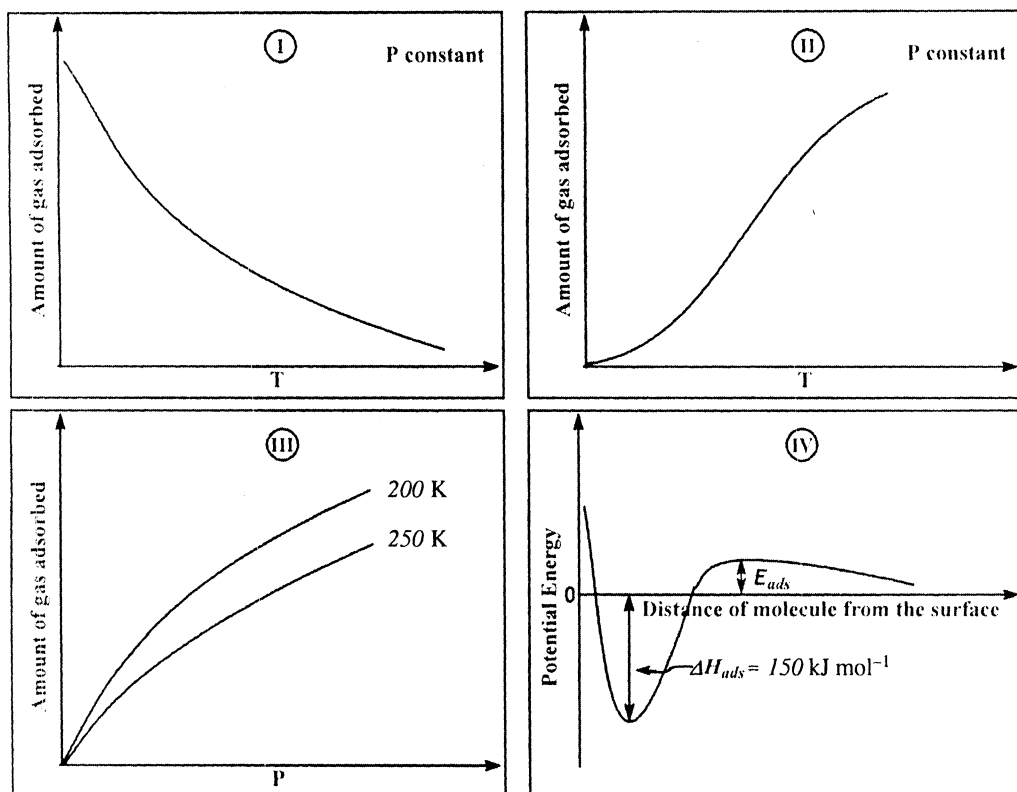

- (A) I is physisorption and II is chemisorption
 (B) I is physisorption and III is chemisorption
 (C) IV is chemisorption and II is chemisorption
 (D) IV is chemisorption and III is chemisorption

ANSWER : AC

37. For the given aqueous reactions, which of the statement(s) is (are) true ?

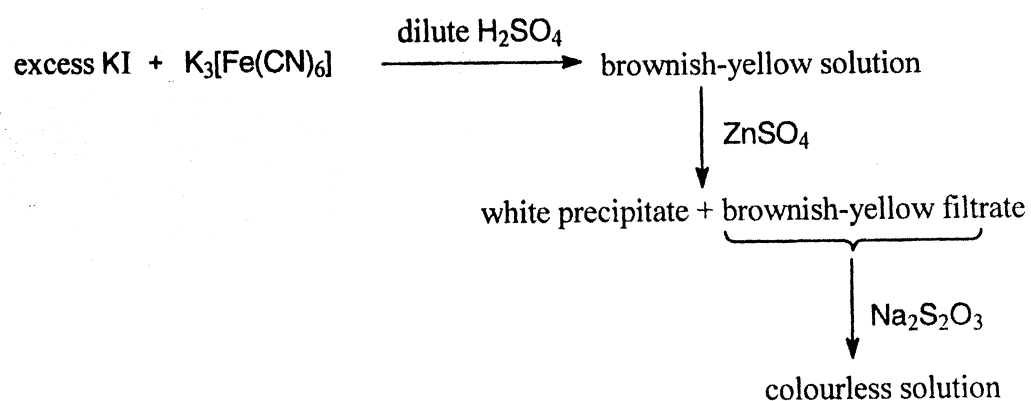

- (A) The first reaction is a redox reaction.
- (B) White precipitate is $\text{Zn}_3[\text{Fe}(\text{CN})_6]_2$.
- (C) Addition of filtrate to starch solution gives blue colour.
- (D) White precipitate is soluble in NaOH solution.

ANSWER : ACD

38. With respect to graphite and diamond, which of the statement(s) given below is (are) correct ?

- (A) Graphite is harder than diamond.
- (B) Graphite has higher electrical conductivity than diamond.
- (C) Graphite has higher thermal conductivity than diamond.
- (D) Graphite has higher C-C bond order than diamond.

ANSWER : BD

39. With reference to the scheme given, which of the given statement(s) about **T**, **U**, **V** and **W** is (are) correct ?

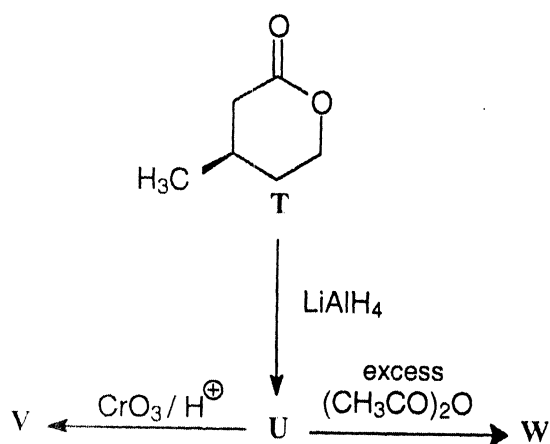

- (A) **T** is soluble in hot aqueous NaOH
- (B) **U** is optically active
- (C) Molecular formula of **W** is $\text{C}_{10}\text{H}_{18}\text{O}_4$
- (D) **V** gives effervescence on treatment with aqueous NaHCO_3

ANSWER : ACD

40. Which of the given statement(s) about N, O, P and Q with respect to M is (are) correct ?

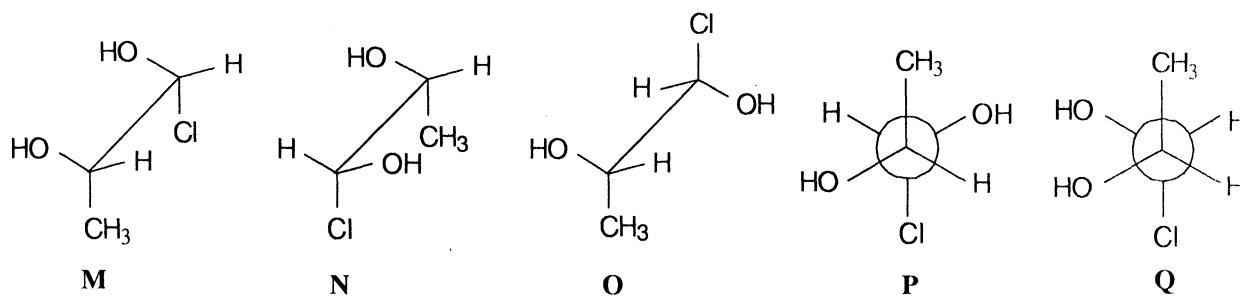

- (A) M and N are non-mirror image stereoisomers
- (B) M and O are identical
- (C) M and P are enantiomers
- (D) M and Q are identical

ANSWER : ABC

PART III : MATHEMATICS

SECTION I : Single Correct Answer Type

This section contains **8 multiple choice questions**. Each question has four choices (A), (B), (C) and (D) out of which **ONLY ONE is correct**.

41. The equation of a plane passing through the line of intersection of the planes

$x + 2y + 3z = 2$ and $x - y + z = 3$ and at a distance $\frac{2}{\sqrt{3}}$ from the point $(3, 1, -1)$ is

(A) $5x - 11y + z = 17$

(B) $\sqrt{2}x + y = 3\sqrt{2} - 1$

(C) $x + y + z = \sqrt{3}$

(D) $x - \sqrt{2}y = 1 - \sqrt{2}$

ANSWER : A

42. Let PQR be a triangle of area Δ with $a = 2$, $b = \frac{7}{2}$ and $c = \frac{5}{2}$, where a , b and c are the lengths of the sides of the triangle opposite to the angles at P , Q and R respectively.

Then $\frac{2 \sin P - \sin 2P}{2 \sin P + \sin 2P}$ equals

(A) $\frac{3}{4\Delta}$

(B) $\frac{45}{4\Delta}$

(C) $\left(\frac{3}{4\Delta}\right)^2$

(D) $\left(\frac{45}{4\Delta}\right)^2$

ANSWER : C

43. If \vec{a} and \vec{b} are vectors such that $|\vec{a} + \vec{b}| = \sqrt{29}$ and $\vec{a} \times (2\hat{i} + 3\hat{j} + 4\hat{k}) = (2\hat{i} + 3\hat{j} + 4\hat{k}) \times \vec{b}$,

then a possible value of $(\vec{a} + \vec{b}) \cdot (-7\hat{i} + 2\hat{j} + 3\hat{k})$ is

(A) 0

(B) 3

(C) 4

(D) 8

ANSWER : C

44. If P is a 3×3 matrix such that $P^T = 2P + I$, where P^T is the transpose of P and I is the 3×3

identity matrix, then there exists a column matrix $X = \begin{bmatrix} x \\ y \\ z \end{bmatrix} \neq \begin{bmatrix} 0 \\ 0 \\ 0 \end{bmatrix}$ such that

- (A) $PX = \begin{bmatrix} 0 \\ 0 \\ 0 \end{bmatrix}$ (B) $PX = X$ (C) $PX = 2X$ (D) $PX = -X$

ANSWER : D

45. Let $\alpha(a)$ and $\beta(a)$ be the roots of the equation

$$(\sqrt[3]{1+a} - 1)x^2 + (\sqrt{1+a} - 1)x + (\sqrt[3]{1+a} - 1) = 0 \text{ where } a > -1.$$

Then $\lim_{a \rightarrow 0^+} \alpha(a)$ and $\lim_{a \rightarrow 0^+} \beta(a)$ are

- (A) $-\frac{5}{2}$ and 1 (B) $-\frac{1}{2}$ and -1 (C) $-\frac{7}{2}$ and 2 (D) $-\frac{9}{2}$ and 3

ANSWER : B

46. Four fair dice D_1, D_2, D_3 and D_4 , each having six faces numbered 1, 2, 3, 4, 5 and 6, are rolled simultaneously. The probability that D_4 shows a number appearing on one of D_1, D_2 and D_3 is

- (A) $\frac{91}{216}$ (B) $\frac{108}{216}$ (C) $\frac{125}{216}$ (D) $\frac{127}{216}$

ANSWER : A

47. The value of the integral

$$\int_{-\pi/2}^{\pi/2} \left(x^2 + \ln \frac{\pi+x}{\pi-x} \right) \cos x \, dx \text{ is}$$

- (A) 0 (B) $\frac{\pi^2}{2} - 4$ (C) $\frac{\pi^2}{2} + 4$ (D) $\frac{\pi^2}{2}$

ANSWER : B

48. Let a_1, a_2, a_3, \dots be in harmonic progression with $a_1 = 5$ and $a_{20} = 25$. The least positive integer n for which $a_n < 0$ is

- (A) 22 (B) 23 (C) 24 (D) 25

ANSWER : D

SECTION II : Paragraph Type

This section contains **6 multiple choice questions** relating to three paragraphs with **two questions on each paragraph**. Each question has four choices (A), (B), (C) and (D) out of which **ONLY ONE is correct**.

Paragraph for Questions 49 and 50

Let a_n denote the number of all n -digit positive integers formed by the digits 0, 1 or both such that no consecutive digits in them are 0. Let $b_n =$ the number of such n -digit integers ending with digit 1 and $c_n =$ the number of such n -digit integers ending with digit 0.

49. The value of b_6 is

- (A) 7 (B) 8 (C) 9 (D) 11

ANSWER : B

50. Which of the following is correct?

- (A) $a_{17} = a_{16} + a_{15}$ (B) $c_{17} \neq c_{16} + c_{15}$ (C) $b_{17} \neq b_{16} + c_{16}$ (D) $a_{17} = c_{17} + b_{16}$

ANSWER : A

Paragraph for Questions 51 and 52

Let $f(x) = (1 - x)^2 \sin^2 x + x^2$ for all $x \in \mathbb{R}$, and let $g(x) = \int_1^x \left(\frac{2(t-1)}{t+1} - \ln t \right) f(t) dt$ for all $x \in (1, \infty)$.

51. Which of the following is true?

- (A) g is increasing on $(1, \infty)$
- (B) g is decreasing on $(1, \infty)$
- (C) g is increasing on $(1, 2)$ and decreasing on $(2, \infty)$
- (D) g is decreasing on $(1, 2)$ and increasing on $(2, \infty)$

ANSWER : B

52. Consider the statements :

P : There exists some $x \in \mathbb{R}$ such that $f(x) + 2x = 2(1 + x^2)$

Q : There exists some $x \in \mathbb{R}$ such that $2f(x) + 1 = 2x(1 + x)$

Then

- (A) both **P** and **Q** are true
- (B) **P** is true and **Q** is false
- (C) **P** is false and **Q** is true
- (D) both **P** and **Q** are false

ANSWER : C

Paragraph for Questions 53 and 54

A tangent PT is drawn to the circle $x^2 + y^2 = 4$ at the point $P(\sqrt{3}, 1)$. A straight line L , perpendicular to PT is a tangent to the circle $(x - 3)^2 + y^2 = 1$.

53. A possible equation of L is

- (A) $x - \sqrt{3}y = 1$ (B) $x + \sqrt{3}y = 1$ (C) $x - \sqrt{3}y = -1$ (D) $x + \sqrt{3}y = 5$

ANSWER : A

54. A common tangent of the two circles is

- (A) $x = 4$ (B) $y = 2$ (C) $x + \sqrt{3}y = 4$ (D) $x + 2\sqrt{2}y = 6$

ANSWER : D

SECTION III : Multiple Correct Answer(s) Type

This section contains **6 multiple choice questions**. Each question has four choices (A), (B), (C) and (D) out of which **ONE or MORE are correct**.

55. For every integer n , let a_n and b_n be real numbers. Let function $f: \mathbb{R} \rightarrow \mathbb{R}$ be given by

$$f(x) = \begin{cases} a_n + \sin \pi x, & \text{for } x \in [2n, 2n + 1] \\ b_n + \cos \pi x, & \text{for } x \in (2n - 1, 2n) \end{cases}, \text{ for all integers } n.$$

If f is continuous, then which of the following hold(s) for all n ?

- (A) $a_{n-1} - b_{n-1} = 0$ (B) $a_n - b_n = 1$ (C) $a_n - b_{n+1} = 1$ (D) $a_{n-1} - b_n = -1$

ANSWER : BD

56. If $f(x) = \int_0^x e^{t^2} (t-2)(t-3) dt$ for all $x \in (0, \infty)$, then

- (A) f has a local maximum at $x = 2$
 (B) f is decreasing on $(2, 3)$
 (C) there exists some $c \in (0, \infty)$ such that $f''(c) = 0$
 (D) f has a local minimum at $x = 3$

ANSWER : ABCD

57. If the straight lines $\frac{x-1}{2} = \frac{y+1}{k} = \frac{z}{2}$ and $\frac{x+1}{5} = \frac{y+1}{2} = \frac{z}{k}$ are coplanar, then the plane(s) containing these two lines is(are)

- (A) $y + 2z = -1$ (B) $y + z = -1$ (C) $y - z = -1$ (D) $y - 2z = -1$

ANSWER : BC

58. Let X and Y be two events such that $P(X | Y) = \frac{1}{2}$, $P(Y | X) = \frac{1}{3}$ and $P(X \cap Y) = \frac{1}{6}$.

Which of the following is (are) correct?

- (A) $P(X \cup Y) = \frac{2}{3}$ (B) X and Y are independent
 (C) X and Y are not independent (D) $P(X^c \cap Y) = \frac{1}{3}$

ANSWER : AB

59. If the adjoint of a 3×3 matrix P is $\begin{bmatrix} 1 & 4 & 4 \\ 2 & 1 & 7 \\ 1 & 1 & 3 \end{bmatrix}$, then the possible value(s) of the determinant of P is (are)

- (A) -2 (B) -1 (C) 1 (D) 2

ANSWER : AD

60. Let $f: (-1, 1) \rightarrow \mathbb{R}$ be such that $f(\cos 4\theta) = \frac{2}{2 - \sec^2 \theta}$ for $\theta \in \left(0, \frac{\pi}{4}\right) \cup \left(\frac{\pi}{4}, \frac{\pi}{2}\right)$. Then the value(s) of $f\left(\frac{1}{3}\right)$ is (are)

- (A) $1 - \sqrt{\frac{3}{2}}$ (B) $1 + \sqrt{\frac{3}{2}}$ (C) $1 - \sqrt{\frac{2}{3}}$ (D) $1 + \sqrt{\frac{2}{3}}$

Zero Marks to all