

FINAL JEE–MAIN EXAMINATION – JANUARY, 2020

(Held On Thursday 09th JANUARY, 2020) TIME : 9 : 30 AM to 12 : 30 PM

PHYSICS

TEST PAPER WITH ANSWER & SOLUTION

1. Consider a force $\vec{F} = -x\hat{i} + y\hat{j}$. The work done by this force in moving a particle from point A(1, 0) to B(0, 1) along the line segment is : (all quantities are in SI units)

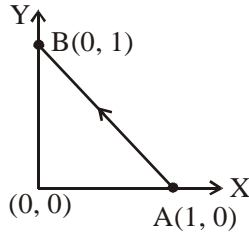

- (1) $\frac{3}{2}$ (2) 1 (3) 2 (4) $\frac{1}{2}$

NTA Ans. (2)

Sol. $W = \int_{\vec{r}_i}^{\vec{r}_f} \vec{F} \cdot d\vec{r}$

$$W = \int_1^0 -x dx + \int_0^1 y dy$$

$$W = \left. \frac{-x^2}{2} \right|_1^0 + \left. \frac{y^2}{2} \right|_0^1$$

$$= -\left(\frac{0^2}{2} - \frac{1^2}{2}\right) + \left(\frac{1^2}{2} - \frac{0^2}{2}\right)$$

$W = 1J$

2. A quantity f is given by $f = \sqrt{\frac{hc^5}{G}}$ where c is speed of light, G universal gravitational constant and h is the Planck's constant. Dimension of f is that of :

- (1) Momentum (2) Area
(3) Energy (4) Volume

NTA Ans. (3)

Sol. $[h] = M^1L^2T^{-1}$

$[C] = L^1T^{-1}$

$[G] = M^{-1}L^3T^{-2}$

$$[f] = \sqrt{\frac{M^1L^2T^{-1} \times L^5T^{-5}}{M^{-1}L^3T^{-2}}} = M^1L^2T^{-2}$$

3. A body A of mass m is moving in a circular orbit of radius R about a planet. Another body B of mass $\frac{m}{2}$ collides with A with a velocity which

is half $\left(\frac{\vec{v}}{2}\right)$ the instantaneous velocity \vec{v} of A.

The collision is completely inelastic. Then, the combined body :

- (1) starts moving in an elliptical orbit around the planet.
(2) continues to move in a circular orbit
(3) Falls vertically downwards towards the planet
(4) Escapes from the Planet's Gravitational field.

NTA Ans. (1)

- Sol. Initially, the body of mass m is moving in a circular orbit of radius R. So it must be moving with orbital speed.

$$v_0 = \sqrt{\frac{GM}{R}}$$

After collision, let the combined mass moves with speed v_1

$$mv_0 + \frac{m}{2} \frac{v_0}{2} = \left(\frac{3m}{2}\right)v_1$$

$$v_1 = \frac{5v_0}{6}$$

Since after collision, the speed is not equal to orbital speed at that point. So motion cannot be circular. Since velocity will remain tangential, so it cannot fall vertically towards the planet. Their speed after collision is less than escape speed $\sqrt{2}v_0$, so they cannot escape gravitational field.

So their motion will be elliptical around the planet.

4. The electric fields of two plane electromagnetic plane waves in vacuum are given by

$$\vec{E}_1 = E_0 \hat{j} \cos(\omega t - kx) \quad \text{and}$$

$$\vec{E}_2 = E_0 \hat{k} \cos(\omega t - ky)$$

At $t = 0$, a particle of charge q is at origin with a velocity $\vec{v} = 0.8c\hat{j}$ (c is the speed of light in vacuum). The instantaneous force experienced by the particle is :

- (1) $E_0 q(-0.8\hat{i} + \hat{j} + \hat{k})$
- (2) $E_0 q(0.8\hat{i} - \hat{j} + 0.4\hat{k})$
- (3) $E_0 q(0.8\hat{i} + \hat{j} + 0.2\hat{k})$
- (4) $E_0 q(0.4\hat{i} - 3\hat{j} + 0.8\hat{k})$

NTA Ans. (3)

Sol. $\vec{E}_1 = E_0 \hat{j} \cos(\omega t - kx)$

Its corresponding magnetic field will be

$$\vec{B}_1 = \frac{E_0}{c} \hat{k} \cos(\omega t - kx)$$

$$\vec{E}_2 = E_0 \hat{k} \cos(\omega t - ky)$$

$$\vec{B}_2 = \frac{E_0}{c} \hat{i} \cos(\omega t - ky)$$

Net force on charge particle

$$= q\vec{E}_1 + q\vec{E}_2 + q\vec{v} \times \vec{B}_1 + q\vec{v} \times \vec{B}_2$$

$$= qE_0 \hat{j} + qE_0 \hat{k} + q(0.8c\hat{j}) \times \left(\frac{E_0}{c} \hat{k} \right) + q(0.8c\hat{j}) \times \left(\frac{E_0}{c} \hat{i} \right)$$

$$= qE_0 \hat{j} + qE_0 \hat{k} + 0.8qE_0 \hat{i} - 0.8qE_0 \hat{k}$$

$$\vec{F} = qE_0 [0.8\hat{i} + \hat{j} + 0.2\hat{k}]$$

5. Consider a sphere of radius R which carries a uniform charge density ρ . If a sphere of radius

$$\frac{R}{2} \text{ is carved out of it, as shown, the ratio } \frac{|\vec{E}_A|}{|\vec{E}_B|}$$

of magnitude of electric field \vec{E}_A and \vec{E}_B , respectively, at points A and B due to the remaining portion is :

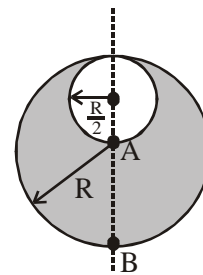

- (1) $\frac{18}{54}$
- (2) $\frac{21}{34}$
- (3) $\frac{17}{54}$
- (4) $\frac{18}{34}$

NTA Ans. (4)

Sol. Fill the empty space with $+\rho$ and $-\rho$ charge density.

$$|E_A| = 0 + \frac{k\rho \cdot \frac{4}{3}\pi \left(\frac{R}{2}\right)^3}{\left(\frac{R}{2}\right)^2} = k\rho \frac{4}{3}\pi \left(\frac{R}{2}\right)$$

$$|E_B| = \frac{k\rho \cdot \frac{4}{3}\pi R^3}{R^2} - \frac{k\rho \cdot \frac{4}{3}\pi \left(\frac{R}{2}\right)^3}{\left(\frac{3R}{2}\right)^2}$$

$$= k\rho \frac{4}{3}\pi R - k\rho \frac{4}{3}\pi \frac{R}{18} = k\rho \frac{4}{3}\pi \left(\frac{17R}{18}\right)$$

$$\frac{E_A}{E_B} = \frac{9}{17} = \frac{18}{34}$$

6. A long, straight wire of radius a carries a current distributed uniformly over its cross-section. The ratio of the magnetic fields due to the wire at distance $\frac{a}{3}$ and $2a$, respectively from the axis of the wire is :

- (1) $\frac{2}{3}$ (2) $\frac{3}{2}$ (3) $\frac{1}{2}$ (4) 2

NTA Ans. (1)

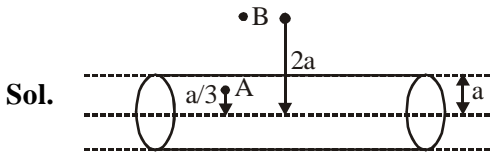

Sol.

Let current density be J .

\therefore Applying Ampere's law.

$$\oint \vec{B} \cdot d\vec{\ell} = \mu_0 i \Rightarrow B_A 2\pi \frac{a}{3} = \mu_0 J \pi \left(\frac{a}{3}\right)^2$$

$$\therefore B_A = \frac{\mu_0 J a}{6}$$

Similarly, $B_B = \frac{\mu_0 J a}{4}$

$$\therefore \frac{B_A}{B_B} = \frac{\mu_0 J a \times 4}{\mu_0 J 6 a} = \frac{2}{3}$$

7. Consider two ideal diatomic gases A and B at some temperature T . Molecules of the gas A are rigid, and have a mass m . Molecules of the gas B have an additional vibrational mode, and have a mass $\frac{m}{4}$. The ratio of the specific heats

(C_V^A and C_V^B) of gas A and B, respectively is :

- (1) 7 : 9 (2) 5 : 7 (3) 3 : 5 (4) 5 : 9

NTA Ans. (2)

- Sol. Degree of freedom of a diatomic molecule if vibration is absent = 5

Degree of freedom of a diatomic molecule if vibration is present = 7

$$\therefore C_v^A = \frac{f_A}{2} R = \frac{5}{2} R \text{ \& } C_v^B = \frac{f_B}{2} R = \frac{7}{2} R$$

$$\therefore \frac{C_v^A}{C_v^B} = \frac{5}{7}$$

8. A particle moving with kinetic energy E has de Broglie wavelength λ . If energy ΔE is added to its energy, the wavelength become $\lambda/2$. Value of ΔE , is :

- (1) $2E$ (2) E (3) $3E$ (4) $4E$

NTA Ans. (3)

- Sol. Given, de-Broglie wavelength = $\frac{h}{\sqrt{2mE}} = \lambda$

$$\text{Also, } \frac{h}{\sqrt{2m(E + \Delta E)}} = \frac{\lambda}{2}$$

$$\therefore \frac{E + \Delta E}{E} = 4 \Rightarrow \Delta E = 3E.$$

9. If the screw on a screw-gauge is given six rotations, it moves by 3 mm on the main scale. If there are 50 divisions on the circular scale the least count of the screw gauge is :

- (1) 0.001 mm (2) 0.001 cm
(3) 0.02 mm (4) 0.01 cm

NTA Ans. (2)

- Sol. Given on six rotation, reading of main scale changes by 3mm.

$$\therefore 1 \text{ rotation corresponds to } \frac{1}{2} \text{ mm}$$

Also no. of division on circular scale = 50.

\therefore Least count of the screw gauge will be

$$\frac{0.5}{50} \text{ mm} = 0.001 \text{ cm.}$$

10. A vessel of depth $2h$ is half filled with a liquid of refractive index $2\sqrt{2}$ and the upper half with another liquid of refractive index $\sqrt{2}$. The liquids are immiscible. The apparent depth of the inner surface of the bottom of vessel will be :

- (1) $\frac{h}{\sqrt{2}}$ (2) $\frac{3}{4}h\sqrt{2}$
 (3) $\frac{h}{2(\sqrt{2}+1)}$ (4) $\frac{h}{3\sqrt{2}}$

NTA Ans. (2)

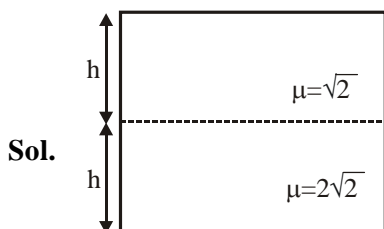

For near normal incidence,

$$h_{app} = \frac{h_{actual}}{\left(\frac{\mu_{in}}{\mu_{ref.}}\right)}$$

$$\therefore h_{apparent} = \frac{\left(\frac{h}{\frac{2\sqrt{2}}{\sqrt{2}}}\right) + h}{1} = \frac{3h}{2\sqrt{2}} = \frac{3}{4}h\sqrt{2}$$

11. Radiation, with wavelength 6561 \AA falls on a metal surface to produce photoelectrons. The electrons are made to enter a uniform magnetic field of $3 \times 10^{-4} \text{ T}$. If the radius of the largest circular path followed by the electrons is 10 mm , the work function of the metal is close to :

- (1) 1.8 eV (2) 1.1 eV
 (3) 0.8 eV (4) 1.6 eV

NTA Ans. (3)

Sol. Let the work function be ϕ .

$$\therefore KE_{max} = \frac{hc}{\lambda} - \phi$$

$$\text{Again, } R_{max} = \frac{\sqrt{2mKE_{max}}}{qB} = \frac{\sqrt{2m\left(\frac{hc}{\lambda} - \phi\right)}}{qB}$$

$$\therefore \frac{R_{max}^2 q^2 B^2}{2m} = \frac{hc}{\lambda} - \phi$$

$$\therefore \phi = \frac{hc}{\lambda} - \frac{R_{max}^2 q^2 B^2}{2m} = 1.0899 \text{ eV} \approx 1.1 \text{ eV}$$

12. The aperture diameter of a telescope is 5 m . The separation between the moon and the earth is $4 \times 10^5 \text{ km}$. With light of wavelength of 5500 \AA , the minimum separation between objects on the surface of moon, so that they are just resolved, is close to :

- (1) 20 m (2) 600 m
 (3) 60 m (4) 200 m

NTA Ans. (3)

Sol. Let distance is x then

$$d\theta = \frac{1.22\lambda}{D} \quad (D = \text{diameter})$$

$$\frac{x}{d} = \frac{1.22\lambda}{D} \quad (d = \text{distance between earth \& moon})$$

$$x = \frac{1.22 \times (5500 \times 10^{-10}) \times (4 \times 10^8)}{5} = 53.68 \text{ m}$$

most appropriate is 60 m .

13. Two particles of equal mass m have respective initial velocities $u\hat{i}$ and $u\left(\frac{\hat{i} + \hat{j}}{2}\right)$. They collide completely inelastically. The energy lost in the process is :

- (1) $\frac{3}{4}mu^2$ (2) $\frac{1}{8}mu^2$ (3) $\sqrt{\frac{2}{3}}mu^2$ (4) $\frac{1}{3}mu^2$

NTA Ans. (2)

Sol. From momentum conservation

$$m\hat{u} + m\hat{u} \left(\frac{\hat{i} + \hat{j}}{2} \right) = (m + m)\bar{v}$$

$$\Rightarrow \bar{v} = \frac{3}{4}u\hat{i} + \frac{u}{4}\hat{j}$$

$$\Rightarrow |\bar{v}| = \frac{u}{4}\sqrt{10}$$

$$\text{Final kinetic energy} = \frac{1}{2}2m \left(\frac{u}{4}\sqrt{10} \right)^2 = \frac{5}{8}mu^2$$

Initial kinetic energy

$$= \frac{1}{2}mu^2 + \frac{1}{2}m \left(\frac{u}{\sqrt{2}} \right)^2 = \frac{6}{8}mu^2$$

$$\text{Loss in K.E.} = k_i - k_f = \frac{1}{8}mu^2$$

14. Which of the following is an equivalent cyclic process corresponding to the thermodynamic cyclic given in the figure? where, 1 → 2 is adiabatic. (Graphs are schematic and are not to scale)

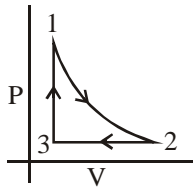

- (1)
- (2)
- (3)
- (4)

NTA Ans. (4)

Sol.

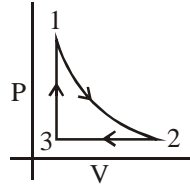

In process 2 to 3 pressure is constant & in process 3 to 1 volume is constant which is correct only in option 4.

Correct graph is

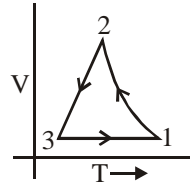

15. In the given circuit diagram, a wire is joining points B and D. The current in this wire is :

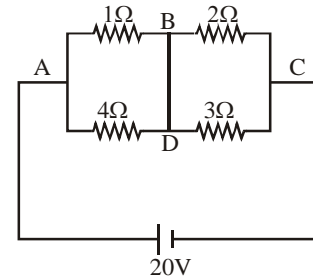

- (1) 4A (2) 2A (3) 0.4A (4) Zero

NTA Ans. (2)

Sol.

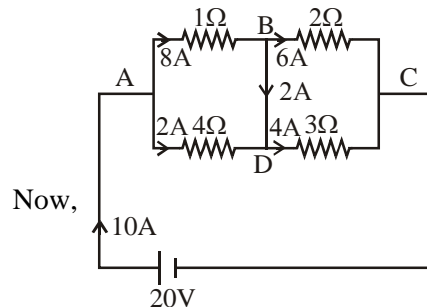
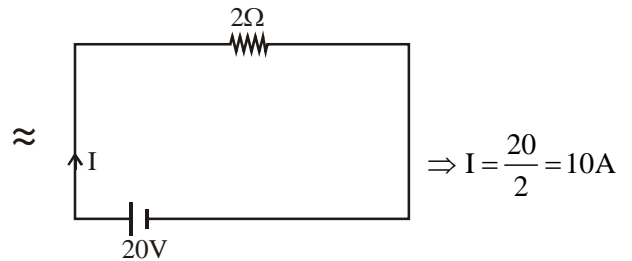
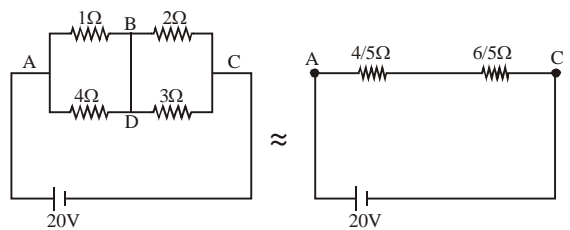

18. An electric dipole of moment $\vec{p} = (-\hat{i} - 3\hat{j} + 2\hat{k}) \times 10^{-29} \text{ C} \cdot \text{m}$ is at the origin (0, 0, 0). The electric field due to this dipole at $\vec{r} = +\hat{i} + 3\hat{j} + 5\hat{k}$ (note that $\vec{r} \cdot \vec{p} = 0$) is parallel to:

- (1) $(-\hat{i} + 3\hat{j} - 2\hat{k})$ (2) $(+\hat{i} - 3\hat{j} - 2\hat{k})$
 (3) $(+\hat{i} + 3\hat{j} - 2\hat{k})$ (4) $(-\hat{i} - 3\hat{j} + 2\hat{k})$

NTA Ans. (3)

Sol. Since \vec{r} and \vec{p} are perpendicular to each other therefore point lies on the equatorial plane. Therefore electric field at the point will be antiparallel to the dipole moment.

i.e. $\vec{E} \parallel -\vec{p}$

$$\vec{E} \parallel (\hat{i} + 3\hat{j} - 2\hat{k})$$

19.

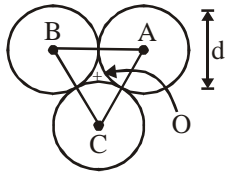

Three solid spheres each of mass m and diameter d are stuck together such that the lines connecting the centres form an equilateral triangle of side of length d . The ratio I_0/I_A of moment of inertia I_0 of the system about an axis passing the centroid and about center of any of the spheres I_A and perpendicular to the plane of the triangle is :

- (1) $\frac{13}{23}$ (2) $\frac{15}{13}$ (3) $\frac{23}{13}$ (4) $\frac{13}{15}$

NTA Ans. (1)

Sol. From parallel axis theorem

$$I_0 = 3 \times \left[\frac{2}{5} M \left(\frac{d}{2} \right)^2 + M \left(\frac{d}{\sqrt{3}} \right)^2 \right] = \frac{13}{10} M d^2$$

$$I_A = I_0 + 3M \left(\frac{d}{\sqrt{3}} \right)^2$$

$$= \frac{13}{10} M d^2 + M d^2$$

$$= \frac{23}{10} M d^2$$

$$\frac{I_0}{I_A} = \frac{13}{23}$$

20. Water flows in a horizontal tube (see figure). The pressure of water changes by 700 Nm^{-2} between A and B where the area of cross section are 40 cm^2 and 20 cm^2 , respectively. Find the rate of flow of water through the tube.

(density of water = 1000 kgm^{-3})

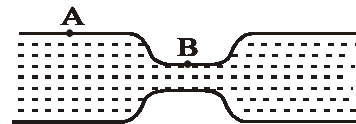

(Fig.)

- (1) $1810 \text{ cm}^3/\text{s}$ (2) $3020 \text{ cm}^3/\text{s}$
 (3) $2720 \text{ cm}^3/\text{s}$ (4) $2420 \text{ cm}^3/\text{s}$

NTA Ans. (3)

Sol. Rate of flow of water = $A_A V_A = A_B V_B$

$$(40)V_A = (20)V_B$$

$$V_B = 2V_A \dots\dots (1)$$

Using Bernoulli's theorem

$$P_A + \frac{1}{2}\rho V_A^2 = P_B + \frac{1}{2}\rho V_B^2$$

$$P_A - P_B = \frac{1}{2}\rho(V_B^2 - V_A^2)$$

$$700 = \frac{1}{2} \times 1000(4V_A^2 - V_A^2)$$

$$V_A = 0.68 \text{ m/s} = 68 \text{ cm/s}$$

Rate of flow = $A_A V_A$

$$= (40)(68) = 2720 \text{ cm}^3/\text{s}$$

- 21.** In a fluorescent lamp choke (a small transformer) 100 V of reverse voltage is produced when the choke current changes uniformly from 0.25 A to 0 in a duration of 0.025 ms. The self-inductance of the choke (in mH) is estimated to be _____ .

NTA Ans. (10.00)

Sol. $V = \left| L \frac{di}{dt} \right|$

$$\Rightarrow L = \frac{V}{\left| \frac{di}{dt} \right|} = \frac{100}{\frac{0.25}{0.025 \times 10^{-3}}} = 10\text{mH}$$

- 22.** One end of a straight uniform 1m long bar is pivoted on horizontal table. It is released from rest when it makes an angle 30° from the horizontal (see figure). Its angular speed when it hits the table is given as $\sqrt{n} \text{ s}^{-1}$, where n is an integer. The value of n is _____ .

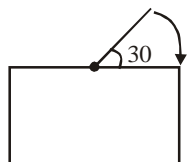

NTA Ans. (15.00)

Sol. P.E. = 0

From mechanical energy conservation,

$$U_i + K_i = U_f + K_f$$

$$\Rightarrow mg \frac{\ell}{2} \sin 30^\circ + 0 = 0 + \frac{1}{2} I \omega^2$$

$$\Rightarrow mg \times \frac{1}{2} \times \frac{1}{2} + 0 = 0 + \frac{1}{2} \times \frac{m(1)^2}{3} \omega^2$$

$$\Rightarrow \omega^2 = \frac{3g}{2} \Rightarrow \omega = \sqrt{15}$$

$$\therefore n = 15$$

- 23.** The distance x covered by a particle in one dimensional motion varies with time t as $x^2 = at^2 + 2bt + c$. If the acceleration of the particle depends on x as x^{-n} , where n is an integer, the value of n is _____ .

NTA Ans. (3.00)

Sol. $x = \sqrt{at^2 + 2bt + c}$

Differentiating w.r.t. time

$$\frac{dx}{dt} = v = \frac{1}{2\sqrt{at^2 + 2bt + c}} \times (2at + 2b)$$

$$\Rightarrow v = \frac{at + b}{x}$$

$$\Rightarrow vx = at + b$$

Differentiating w.r.t. x

$$\Rightarrow \frac{dv}{dx} \times x + v = a \times \frac{dt}{dx}$$

Multiply both side by v

$$\Rightarrow \left(v \frac{dv}{dx} \right) x + v^2 = a$$

$$\Rightarrow a'x = a - v^2 \text{ [Here } a' \text{ is acceleration]}$$

$$\Rightarrow a'x = a - \left(\frac{at + b}{x} \right)^2$$

$$\Rightarrow a'x = \frac{ax^2 - (at + b)^2}{x^2}$$

$$\Rightarrow a'x = \frac{a(at^2 + 2bt + c) - (at + b)^2}{x^2}$$

$$\Rightarrow a'x = \frac{ac - b^2}{x^2}$$

$$\Rightarrow a' = \frac{ac - b^2}{x^3}$$

$$\therefore a' \propto \frac{1}{x^3} \quad \therefore n = 3$$

24. A body of mass $m = 10 \text{ kg}$ is attached to one end of a wire of length 0.3 m . The maximum angular speed (in rad s^{-1}) with which it can be rotated about its other end in space station is (Breaking stress of wire = $4.8 \times 10^7 \text{ Nm}^{-2}$ and area of cross-section of the wire = 10^{-2} cm^2) is:

NTA Ans. (4.00)

Sol. $T = m\omega^2 \ell$

$$\text{Breaking stress} = \frac{T}{A} = \frac{m\omega^2 \ell}{A}$$

$$\Rightarrow \omega^2 = \frac{4.8 \times 10^7 \times (10^{-2} \times 10^{-4})}{10 \times 0.3} = 16$$

$$\Rightarrow \omega = 4$$

25. Both the diodes used in the circuit shown are assumed to be ideal and have negligible resistance when these are forward biased. Built in potential in each diode is 0.7 V . For the input voltages shown in the figure, the voltage (in Volts) at point A is _____ .

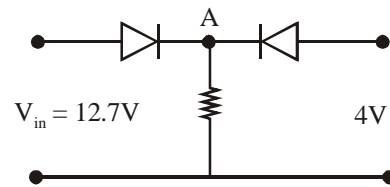

NTA Ans. (12.00)

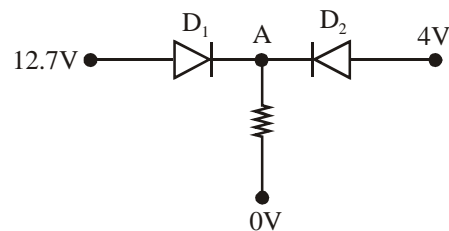

Sol.

Diode D_1 is forward biased and D_2 is reverse biased.

$$\therefore V_A = 12.7 - 0.7 = 12\text{V}.$$

FINAL JEE-MAIN EXAMINATION – JANUARY, 2020

(Held On Thursday 09th JANUARY, 2020) TIME : 9 : 30 AM to 12 : 30 PM

CHEMISTRY

TEST PAPER WITH ANSWER & SOLUTION

1. Identify (A) in the following reaction sequence :

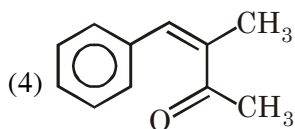
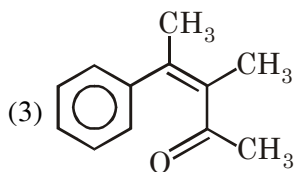
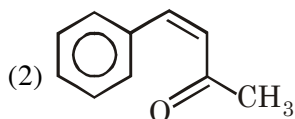
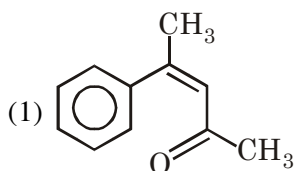
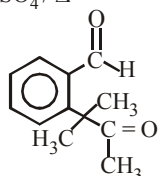
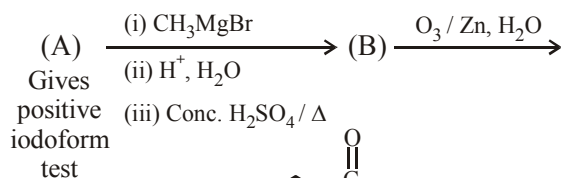

NTA Ans. (4)

Sol.

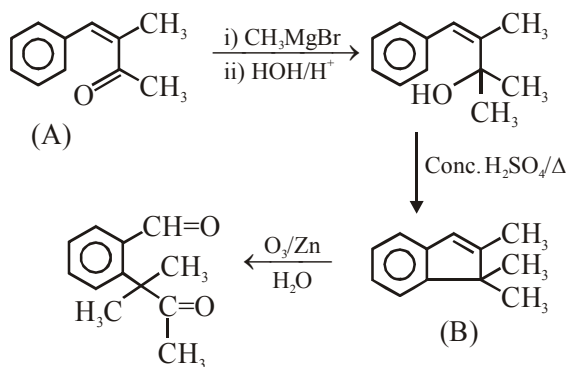

2. For the following reactions

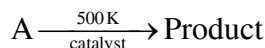
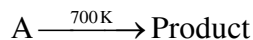

it was found that E_a is decreased by 30 kJ/mol in the presence of catalyst.

If the rate remains unchanged, the activation energy for catalysed reaction is (Assume pre exponential factor is same):

- (1) 135 kJ/mol (2) 105 kJ/mol
(3) 198 kJ/mol (4) 75 kJ/mol

NTA Ans. (4)

Sol. $K_1 = A e^{-\frac{E_a}{R \times 700}}$

$K_2 = A \times e^{-\frac{(E_a-30)}{R \times 500}}$

For same rate

$K_1 = K_2$

$e^{-\frac{E_a}{700R}} = e^{-\frac{(E_a-30)}{R \times 500}}$

$\frac{E_a}{700R} = \frac{E_a - 30}{R \times 500}$

$5E_a = 7E_a - 210$

$210 = 2E_a$

$E_a = 105 \text{ kJ/mole}$

$E_a - 30 = 75$

3. The correct order of heat of combustion for following alkadienes is :



- (1) (a) < (b) < (c) (2) (b) < (c) < (a)
(3) (c) < (b) < (a) (4) (a) < (c) < (b)

NTA Ans. (1)

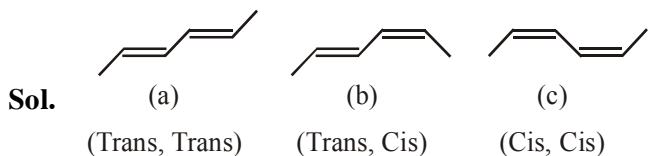

∴ Generally trans is more stable than cis form.

$$\text{Heat of combustion (HOC)} \propto \frac{1}{\text{Stability}}$$

Stability : a > b > c

HOC : c > b > a

4. A chemist has 4 samples of artificial sweetener A, B, C and D. To identify these samples, he performed certain experiments and noted the following observations :

- (i) A and D both form blue-violet colour with ninhydrin.
- (ii) Lassaigne extract of C gives positive AgNO_3 test and negative $\text{Fe}_4[\text{Fe}(\text{CN})_6]_3$ test.
- (iii) Lassaigne extract of B and D gives positive sodium nitroprusside test

Based on these observations which option is correct ?

- (1) A : Aspartame ; B : Saccharin ;
C : Sucralose ; D ; Alitame
- (2) A : Alitame ; B : Saccharin ;
C : Aspartame ; D ; Sucralose
- (3) A : Saccharin ; B : Alitame ;
C : Sucralose ; D ; Aspartame
- (4) A : Aspartame ; B : Alitame ;
C : Saccharin ; D ; Sucralose

NTA Ans. (1)

- Sol. (i) Blue violet color with Ninhydrine → amino acid derivative. So it cannot be saccharide or sucralose.
- (ii) Lassaigne extract give +ve test with AgNO_3 . So Cl is present, -ve test with $\text{Fe}_4[\text{Fe}(\text{CN})_6]_3$ means N is absent. So it can't be Aspartame or Saccharine or Alitame, so C is sucralose.

(iii) Lassaigne solution of B and D given +ve sodium nitroprusside test, so it is having S, so it is Saccharine and Alitame.

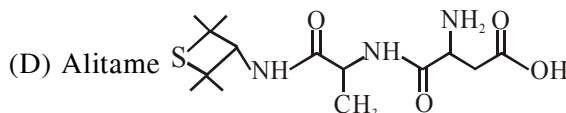
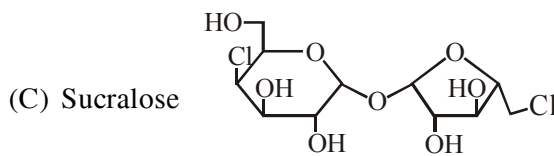
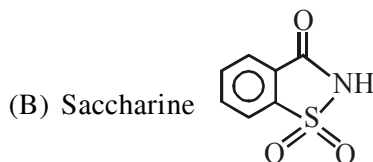
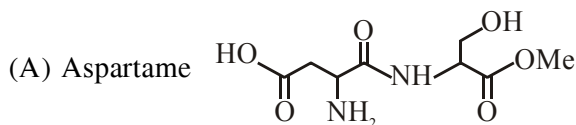

5. 'X' melts at low temperature and is a bad conductor of electricity in both liquid and solid state. X is :

- (1) Carbon tetrachloride
- (2) Mercury
- (3) Silicon carbide
- (4) Zinc sulphide

NTA Ans. (1)

Sol. CCl_4 is molecular solid so does not conduct electricity in liquid & solid state.

6. According to the following diagram, A reduces BO_2 when the temperature is :

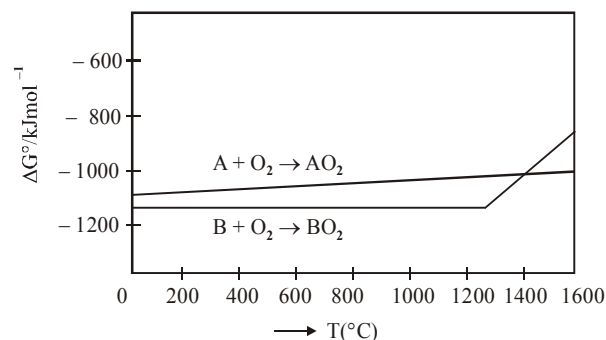

- (1) < 1400 °C
- (2) > 1400 °C
- (3) < 1200 °C
- (4) > 1200 °C but < 1400 °C

NTA Ans. (2)

Sol. A reduces BO_2 when temperature is above 1400°C because above 1400°C A has more –ve ΔG° for AO_2 formation than B to BO_2 formation.

7. The K_{sp} for the following dissociation is 1.6×10^{-5}

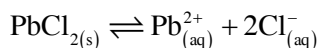

Which of the following choices is correct for a mixture of 300 mL 0.134 M $\text{Pb}(\text{NO}_3)_2$ and 100 mL 0.4 M NaCl ?

- (1) $Q < K_{sp}$
- (2) $Q > K_{sp}$
- (3) $Q = K_{sp}$
- (4) Not enough data provided

NTA Ans. (2)

Sol.
$$[\text{Pb}^{2+}] = \frac{300 \times 0.134}{400}$$

$$= 1.005 \times 10^{-1} \text{ M}$$

$$[\text{Cl}^-] = \frac{100 \times 0.4}{400}$$

$$= 10^{-1} \text{ M}$$

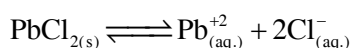

$$Q = [\text{Pb}^{2+}] \times [\text{Cl}^-]^2$$

$$= 1.005 \times 10^{-3} > k_{sp}$$

8. $[\text{Pd}(\text{F})(\text{Cl})(\text{Br})(\text{I})]^{2-}$ has n number of geometrical isomers. Then, the spin-only magnetic moment and crystal field stabilisation energy [CFSE] of $[\text{Fe}(\text{CN})_6]^{n-6}$, respectively, are:

[Note : Ignore the pairing energy]

- (1) 2.84 BM and $-1.6 \Delta_0$
- (2) 1.73 BM and $-2.0 \Delta_0$
- (3) 0 BM and $-2.4 \Delta_0$
- (4) 5.92 BM and 0

NTA Ans. (2)

Sol. $[\text{Pb}(\text{F})(\text{Cl})(\text{Br})(\text{I})]^{2-}$ have three geometrical isomer so formula for $[\text{Fe}(\text{CN})_6]^{n-6}$ is $[\text{Fe}(\text{CN})_6]^{3-}$ and CFSE for this complex is $\text{Fe}^{3\oplus} \Rightarrow 3d^5 4s^0$

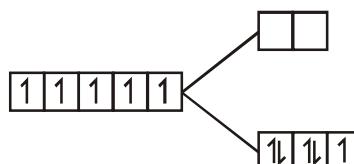

$$\text{Magnetic Moment} = \sqrt{3}$$

$$= 1.73 \text{ B.M}$$

$$\text{CFSE} = [(-0.4 \times 5) + (0.6 \times 0)] \Delta_0$$

$$= -2.0 \Delta_0$$

9. If the magnetic moment of a dioxygen species is 1.73 B.M, it may be :

- (1) O_2^- or O_2^+
- (2) O_2 or O_2^+
- (3) O_2 or O_2^-
- (4) O_2 , O_2^- or O_2^+

NTA Ans. (1)

Sol.	number of unpaired electron	magnetic moment
O_2^\ominus	1	1.73 B.M
O_2^\oplus	1	1.73 B.M
O_2	2	2.83 BM

10. If enthalpy of atomisation for $\text{Br}_{2(1)}$ is x kJ/mol and bond enthalpy for Br_2 is y kJ/mol, the relation between them :

- (1) is $x = y$
- (2) is $x < y$
- (3) does not exist
- (4) is $x > y$

NTA Ans. (4)

Sol. Enthalpy of atomisation of $\text{Br}_2(l)$

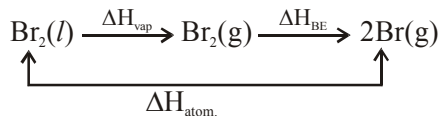

$$\Delta H_{\text{atom}} = \Delta H_{\text{vap}} + \Delta H_{\text{BE}}$$

$$x = \Delta H_{\text{vap}} + y$$

So, $x > y$

11. The increasing order of basicity for the following intermediates is (from weak to strong)

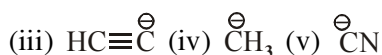
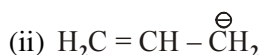
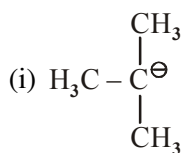

(1) (v) < (i) < (iv) < (ii) < (iii)

(2) (iii) < (i) < (ii) < (iv) < (v)

(3) (v) < (iii) < (ii) < (iv) < (i)

(4) (iii) < (iv) < (ii) < (i) < (v)

NTA Ans. (3)

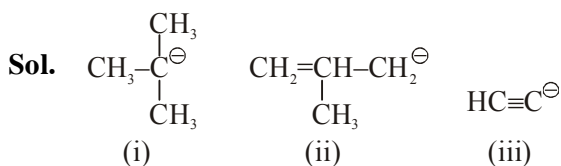

Basic strength order : (i) > (iv) > (ii) > (iii) > (v)

12. B has a smaller first ionization enthalpy than Be. Consider the following statements :

(I) It is easier to remove 2p electron than 2s electron

(II) 2p electron of B is more shielded from the nucleus by the inner core of electrons than the 2s electrons of Be.

(III) 2s electron has more penetration power than 2p electron.

(IV) atomic radius of B is more than Be

(Atomic number B = 5, Be = 4)

The correct statements are :

(1) (I), (II) and (III)

(2) (II), (III) and (IV)

(3) (I), (III) and (IV)

(4) (I), (II) and (IV)

NTA Ans. (1)

Sol. $\text{Be} \Rightarrow 1s^2 2s^2$

$\text{B} \Rightarrow 1s^2 2s^2 2p^1$

B has a smaller size than Be

it is easier to remove 2p electron than 2s electron due to less penetration effect of 2p than 2s.

2p electron of Boron is more shielded from the nucleus by the inner core of electron than the 2s electron of Be

B has a smaller size than Be

13. The acidic, basic and amphoteric oxides, respectively, are :

(1) MgO , Cl_2O , Al_2O_3

(2) Cl_2O , CaO , P_4O_{10}

(3) Na_2O , SO_3 , Al_2O_3

(4) N_2O_3 , Li_2O , Al_2O_3

NTA Ans. (4)

- Sol.** 1. MgO Basic
 Cl₂O Acidic
 Al₂O₃ amphoteric
 2. Cl₂O Acidic
 CaO Basic
 P₄O₁₀ Acidic
 3. Na₂O Basic
 SO₃ Acidic
 Al₂O₃ amphoteric
 4. N₂O₃ Acidic
 Li₂O Basic
 Al₂O₃ amphoteric

14. The major product Z obtained in the following reaction scheme is :

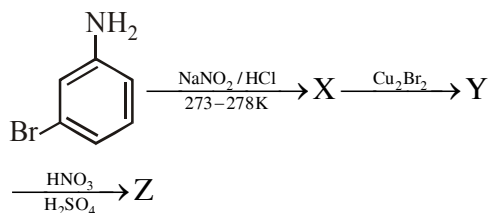

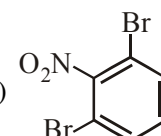
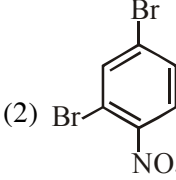
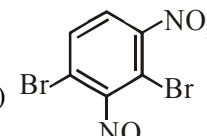
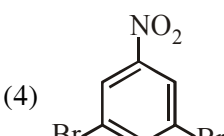
- (1)  (2) 
 (3)  (4) 

NTA Ans. (2)

Sol.

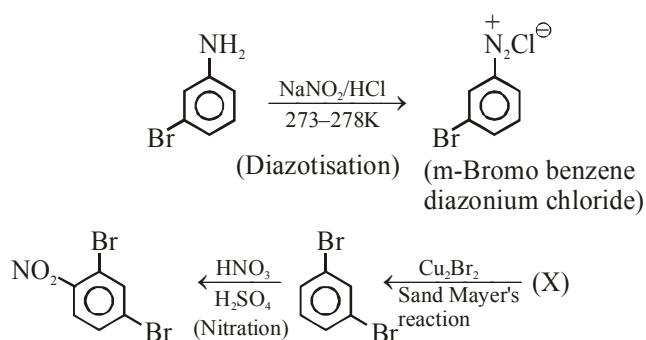

15. Which of these will produce the highest yield in Friedel Crafts reaction?

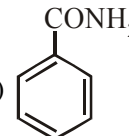
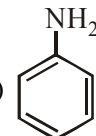
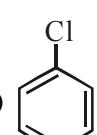
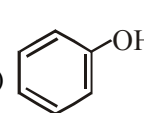
- (1)  (2) 
 (3)  (4) 

NTA Ans. (3)

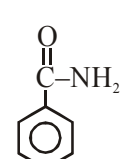
Sol. ∴  (Deactivated ring due to -R effect of amide)

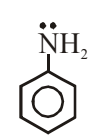
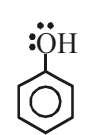
 ,  (l.p.e. of -NH₂ and -OH group do acid-base reaction with lewis acid AlCl₃, so ring is deactivated)

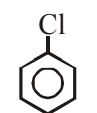
 (Highest yield produced)

16. The major product (Y) in the following reactions is :

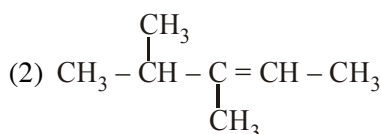
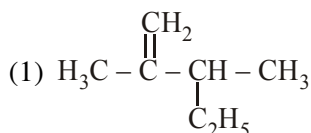
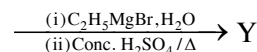
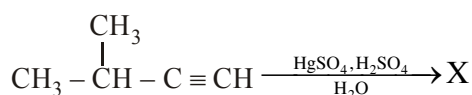

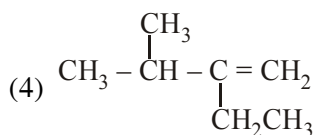
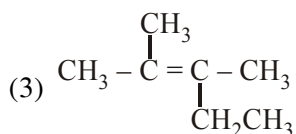

NTA Ans. (3)

Sol.

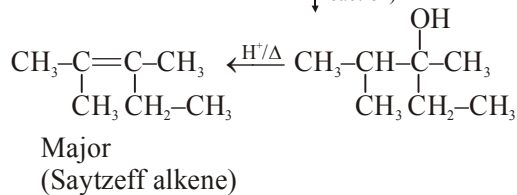
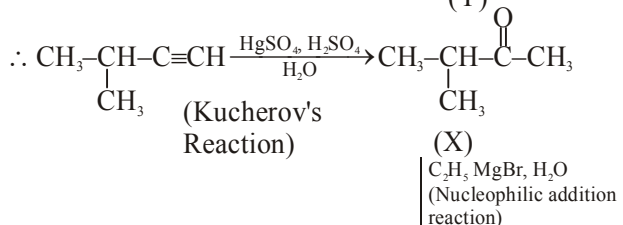
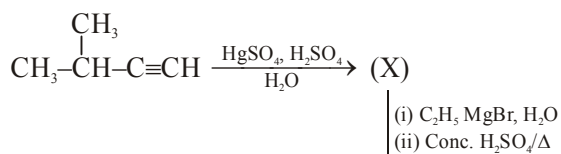

17. Complex X of composition $\text{Cr}(\text{H}_2\text{O})_6\text{Cl}_n$ has a spin only magnetic moment of 3.83 BM. It reacts with AgNO_3 and shows geometrical isomerism. The IUPAC nomenclature of X is :

- (1) Tetraaquadichlorido chromium (III) chloride dihydrate
- (2) Hexaqua chromium (III) chloride
- (3) Dichloridotetraqua chromium (IV) chloride dihydrate
- (4) Tetraaquadichlorido chromium(IV) chloride dihydrate

NTA Ans. (1)

Sol. $\text{Cr}(\text{H}_2\text{O})_6\text{Cl}_n$

if magnetic moment is 3.83 BM then it contains three unpaired electrons. It means chromium in +3 oxidation state so molecular formula is $\text{Cr}(\text{H}_2\text{O})_6\text{Cl}_3$

\therefore This formula has following isomers

- (a) $[\text{Cr}(\text{H}_2\text{O})_6]\text{Cl}_3$: reacts with AgNO_3 but does not show geometrical isomerism.
- (b) $[\text{Cr}(\text{H}_2\text{O})_5\text{Cl}]\text{Cl}_2 \cdot 2\text{H}_2\text{O}$ reacts with AgNO_3 but does not show geometrical isomerism.
- (c) $[\text{Cr}(\text{H}_2\text{O})_4\text{Cl}_2]\text{Cl} \cdot 2\text{H}_2\text{O}$ reacts with AgNO_3 & shows geometrical isomerism.
- (d) $[\text{Cr}(\text{H}_2\text{O})_3\text{Cl}_3] \cdot 3\text{H}_2\text{O}$ does not react with AgNO_3 & shows geometrical isomerism.

$[\text{Cr}(\text{H}_2\text{O})_4\text{Cl}_2]\text{Cl} \cdot 2\text{H}_2\text{O}$ reacts with AgNO_3 & shows geometrical isomerism and its IUPAC nomenclature is Tetraaquadichlorido chromium (III) chloride dihydrate.

18. The compound that cannot act both as oxidising and reducing agent is :

- (1) H_2O_2
- (2) H_2SO_3
- (3) HNO_2
- (4) H_3PO_4

NTA Ans. (4)

- Sol. (i) H_2O_2 acts as oxidising agent as well as reducing agent depending on condition.
 (ii) H_2SO_3 acts as oxidising agent as well as reducing agent depending on condition.
 (iii) HNO_2 acts as oxidising agent as well as reducing agent depending on condition.
 (iv) H_3PO_4 can not act both as oxidising and reducing agent.

H_3PO_4 can act as only oxidising agent.

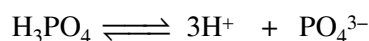

19. The de Broglie wavelength of an electron in the 4th Bohr orbit is :

- (1) $8\pi a_0$
- (2) $2\pi a_0$
- (3) $4\pi a_0$
- (4) $6\pi a_0$

NTA Ans. (1)

Sol. $2\pi r = n\lambda$

for $n = 1, r = a_0$

$n = 4, r = 16a_0$

So, $2\pi \times 16a_0 = 4 \times \lambda$

$\lambda = 8\pi a_0$

20. The electronic configurations of bivalent europium and trivalent cerium are

(atomic number : Xe = 54, Ce = 58, Eu = 63)

- (1) [Xe] $4f^4$ and [Xe] $4f^9$
- (2) [Xe] $4f^7$ and [Xe] $4f^1$
- (3) [Xe] $4f^7 6s^2$ and [Xe] $4f^2 6s^2$
- (4) [Xe] $4f^2$ and [Xe] $4f^7$

NTA Ans. (2)

Sol. $\text{Eu}_{63} \Rightarrow [\text{Xe}] 4f^7 5d^0 6s^2$

$\text{Eu}^{2\oplus} \Rightarrow [\text{Xe}] 4f^7$

$\text{Ce}_{58} \Rightarrow [\text{Xe}] 4f^1 5d^1 6s^2$

$\text{Ce}^{3\oplus} \Rightarrow [\text{Xe}] 4f^1$

21. The hardness of a water sample containing 10^{-3} M MgSO_4 expressed as CaCO_3 equivalents (in ppm) is _____.

(molar mass of MgSO_4 is 120.37 g/mol)

NTA Ans. (100 to 100)

Sol. 1 Litre has 10^{-3} moles MgSO_4

So, 1000 litre has 1 mole MgSO_4

= 1 mole CaCO_3

= 100 ppm

22. The molarity of HNO_3 in a sample which has density 1.4 g/mL and mass percentage of 63% is _____. (Molecular Weight of $\text{HNO}_3 = 63$)

NTA Ans. (14.00 to 14.00)

Sol. 100 gm soln \rightarrow 63 gm HNO_3

$\frac{100}{1.4}$ mL \rightarrow 1 mole HNO_3

Molarity = $\frac{1}{\frac{100}{1.4} \times \frac{1}{1000}} = 14\text{M}$

23. 108 g of silver (molar mass 108 g mol^{-1}) is deposited at cathode from $\text{AgNO}_3(\text{aq})$ solution by a certain quantity of electricity. The volume (in L) of oxygen gas produced at 273 K and 1 bar pressure from water by the same quantity of electricity is _____.

NTA Ans. (5.66 to 5.67)

Sol. gm eq. of Ag = $\frac{108}{108} = 1$

gm eq. of $\text{O}_2(\text{g}) = 1$

Volume of $\text{O}_2(\text{g}) = 22.7 \times \frac{1}{4} = 5.675$ litre

24. The mass percentage of nitrogen in histamine is _____.

NTA Ans. (37.80 to 38.20)

Sol.

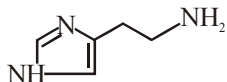

M.F. of Histamine is $C_5H_9N_3$

Molecular mass of Histamine is 111

$$\begin{aligned} \text{Now, mass \% of nitrogen} &= \left(\frac{42}{111} \right) \times 100 \\ &= 37.84\% \end{aligned}$$

25. How much amount of NaCl should be added to 600 g of water ($\rho = 1.00 \text{ g/mL}$) to decrease the freezing point of water to $-0.2 \text{ }^\circ\text{C}$? _____ . (The freezing point depression constant for water = 2K kg mol^{-1})

NTA Ans. (1.74 to 1.76)

Sol. $\Delta T_f = i \times m \times K_f$

$$0.2 = 2 \times 2 \times \frac{w/58.5}{600/1000}$$

$$w = 1.755 \text{ gm}$$

FINAL JEE-MAIN EXAMINATION – JANUARY, 2020

(Held On Thursday 09th JANUARY, 2020) TIME : 9 : 30 AM to 12 : 30 PM

MATHEMATICS

TEST PAPER WITH ANSWER & SOLUTION

1. A spherical iron ball of 10 cm radius is coated with a layer of ice of uniform thickness the melts at a rate of 50 cm³/min. When the thickness of ice is 5 cm, then the rate (in cm/min.) at which the thickness of ice decreases, is :

- (1) $\frac{1}{36\pi}$ (2) $\frac{5}{6\pi}$ (3) $\frac{1}{18\pi}$ (4) $\frac{1}{54\pi}$

NTA Ans. (3)

Sol. Let thickness of ice be 'h'.

$$\text{Vol. of ice} = v = \frac{4\pi}{3}((10+h)^3 - 10^3)$$

$$\frac{dv}{dt} = \frac{4\pi}{3}(3(10+h)^2) \cdot \frac{dh}{dt}$$

Given $\frac{dv}{dt} = 50 \text{ cm}^3 / \text{min}$ and $h = 5 \text{ cm}$

$$\Rightarrow 50 = \frac{4\pi}{3}(3(10+5)^2) \frac{dh}{dt}$$

$$\Rightarrow \frac{dh}{dt} = \frac{50}{4\pi \times 15^2} = \frac{1}{18\pi} \text{ cm/min}$$

2. If the number of five digit numbers with distinct digits and 2 at the 10th place is 336 k, then k is equal to :

- (1) 8 (2) 6 (3) 4 (4) 7

NTA Ans. (1)

Sol. _ _ _ 2 _

No. of five digits numbers =

No. of ways of filling remaining 4 places

$$= 8 \times 8 \times 7 \times 6$$

$$\therefore k = \frac{8 \times 8 \times 7 \times 6}{336} = 8$$

3. Let z be complex number such that $\left| \frac{z-i}{z+2i} \right| = 1$ and $|z| = \frac{5}{2}$. Then the value of $|z + 3i|$ is :

- (1) $\sqrt{10}$ (2) $2\sqrt{3}$ (3) $\frac{7}{2}$ (4) $\frac{15}{4}$

NTA Ans. (3)

Sol. $\left| \frac{z-i}{z+2i} \right| = 1$

$$\Rightarrow |z - i| = |z + 2i|$$

$\Rightarrow z$ lies on perpendicular bisector of (0, 1) and (0, -2).

$$\Rightarrow \text{Im}z = -\frac{1}{2}$$

Let $z = x - \frac{i}{2}$

$$\therefore |z| = \frac{5}{2} \Rightarrow x^2 = 6$$

$$\therefore |z + 3i| = \left| x + \frac{5i}{2} \right| = \sqrt{x^2 + \frac{25}{4}}$$

$$= \sqrt{6 + \frac{25}{4}} = \frac{7}{2}$$

4. In a box, there are 20 cards, out of which 10 are labelled as A and the remaining 10 are labelled as B. Cards are drawn at random, one after the other and with replacement, till a second A-card is obtained. The probability that the second A-card appears before the third B-card is :

- (1) $\frac{11}{16}$ (2) $\frac{13}{16}$ (3) $\frac{9}{16}$ (4) $\frac{15}{16}$

NTA Ans. (1)

Sol. A : Event when card A is drawn
B : Event when card B is drawn.

$$P(A) = P(B) = \frac{1}{2}$$

Required probability = P(AA or (AB)A or (BA)A or (ABB)A or (BAB)A or (BBA)A)

$$= \frac{1}{2} \times \frac{1}{2} + \left(\frac{1}{2} \times \frac{1}{2} \times \frac{1}{2}\right) \times 2 + \left(\frac{1}{2} \times \frac{1}{2} \times \frac{1}{2} \times \frac{1}{2}\right) \times 3$$

$$= \frac{1}{4} + \frac{1}{4} + \frac{3}{16} = \frac{11}{16}$$

5. The value of $\int_0^{2\pi} \frac{x \sin^8 x}{\sin^8 x + \cos^8 x} dx$ is equal to :

- (1) 2π (2) 4π (3) $2\pi^2$ (4) π^2

NTA Ans. (4)

Sol. $I = \int_0^{2\pi} \frac{x \sin^8 x}{\sin^8 x + \cos^8 x} dx$ (1)

$$= \left[\int_0^{\pi} \frac{x \sin^8 x}{\sin^8 x + \cos^8 x} dx + \int_0^{\pi} \frac{(2\pi - x) \sin^8 x}{\sin^8 x + \cos^8 x} dx \right]$$

$$= 2\pi \int_0^{\pi} \frac{\sin^8 x}{\sin^8 x + \cos^8 x} dx$$

$$I = 2\pi \left[\int_0^{\pi/2} \frac{\sin^8 x}{\sin^8 x + \cos^8 x} dx + \int_0^{\pi/2} \frac{\cos^8 x dx}{\sin^8 x + \cos^8 x} dx \right]$$

$$= 2\pi \int_0^{\pi/2} 1 dx = 2\pi \cdot \frac{\pi}{2} = \pi^2$$

6. If $f'(x) = \tan^{-1}(\sec x + \tan x)$, $-\frac{\pi}{2} < x < \frac{\pi}{2}$, and

$f(0) = 0$, then $f(1)$ is equal to :

(1) $\frac{\pi-1}{4}$ (2) $\frac{\pi+2}{4}$

(3) $\frac{\pi+1}{4}$ (4) $\frac{1}{4}$

NTA Ans. (3)

Sol. $f'(x) = \tan^{-1}(\sec x + \tan x)$

$$f'(x) = \tan^{-1}\left(\frac{1 + \sin x}{\cos x}\right) = \tan^{-1}\left(\frac{1 + \tan \frac{x}{2}}{1 - \tan \frac{x}{2}}\right)$$

$$= \tan^{-1}\left(\tan\left(\frac{\pi}{4} + \frac{x}{2}\right)\right)$$

$$\therefore -\frac{\pi}{2} < x < \frac{\pi}{2} \Rightarrow 0 < \frac{\pi}{4} + \frac{x}{2} < \frac{\pi}{2}$$

$$\Rightarrow f'(x) = \frac{\pi}{4} + \frac{x}{2}$$

$$\therefore f(x) = \frac{\pi}{4} \cdot x + \frac{x^2}{4} + c$$

$$\therefore f(0) = 0 \Rightarrow c = 0$$

$$\Rightarrow f(x) = \frac{\pi}{4}x + \frac{x^2}{4}$$

$$\therefore f(1) = \frac{\pi+1}{4}$$

7. If the matrices $A = \begin{bmatrix} 1 & 1 & 2 \\ 1 & 3 & 4 \\ 1 & -1 & 3 \end{bmatrix}$, $B = \text{adj}A$ and

$C = 3A$, then $\frac{|\text{adj}B|}{|C|}$ is equal to :

- (1) 72 (2) 2 (3) 8 (4) 16

NTA Ans. (3)

Sol. $A = \begin{bmatrix} 1 & 1 & 2 \\ 1 & 3 & 4 \\ 1 & -1 & 3 \end{bmatrix}$

$$\Rightarrow |A| = 6$$

$$\frac{|\text{adj}B|}{|c|} = \frac{|\text{adj}(\text{adj}A)|}{|9A|} = \frac{|A|^4}{3^3 |A|} = \frac{|A|^3}{3^3}$$

$$= \frac{(6)^3}{(3)^3} = 8$$

8. The number of real roots of the equation, $e^{4x} + e^{3x} - 4e^{2x} + e^x + 1 = 0$ is :

- (1) 4 (2) 2 (3) 3 (4) 1

NTA Ans. (4)

13. If e_1 and e_2 are the eccentricities of the ellipse, $\frac{x^2}{18} + \frac{y^2}{4} = 1$ and the hyperbola, $\frac{x^2}{9} - \frac{y^2}{4} = 1$ respectively and (e_1, e_2) is a point on the ellipse, $15x^2 + 3y^2 = k$, then k is equal to :

- (1) 15 (2) 14 (3) 17 (4) 16

NTA Ans. (4)

Sol. $e_1 = \sqrt{1 - \frac{4}{18}} = \frac{\sqrt{7}}{3}$

$e_2 = \sqrt{1 + \frac{4}{9}} = \frac{\sqrt{13}}{3}$

$\therefore (e_1, e_2)$ lies on $15x^2 + 3y^2 = k$

$\Rightarrow 15e_1^2 + 3e_2^2 = k$

$\Rightarrow k = 16$

14. Let f be any function continuous on $[a, b]$ and twice differentiable on (a, b) . If for all $x \in (a, b)$, $f'(x) > 0$ and $f''(x) < 0$, then for any $c \in (a, b)$, $\frac{f(c) - f(a)}{f(b) - f(c)}$ is greater than :

- (1) $\frac{b+a}{b-a}$ (2) $\frac{b-c}{c-a}$ (3) $\frac{c-a}{b-c}$ (4) 1

NTA Ans. (3)

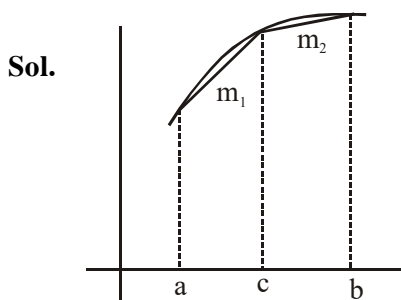

it is clear from graph that $m_1 > m_2$

$\Rightarrow \frac{f(c) - f(a)}{c - a} > \frac{f(b) - f(c)}{b - c}$

$\Rightarrow \frac{f(c) - f(a)}{f(b) - f(c)} > \frac{c - a}{b - c}$

15. If for some α and β in \mathbb{R} , the intersection of the following three planes

$x + 4y - 2z = 1$

$x + 7y - 5z = \beta$

$x + 5y + \alpha z = 5$

is a line in \mathbb{R}^3 , then $\alpha + \beta$ is equal to :

- (1) 10 (2) -10 (3) 2 (4) 0

NTA Ans. (1)

Sol. For planes to intersect on a line

\Rightarrow there should be infinite solution of the given system of equations

for infinite solutions

$\Delta = \begin{vmatrix} 1 & 4 & -2 \\ 1 & 7 & -5 \\ 1 & 5 & \alpha \end{vmatrix} = 0 \Rightarrow 3\alpha + 9 = 0 \Rightarrow \alpha = -3$

$\Delta_z = \begin{vmatrix} 1 & 4 & 1 \\ 1 & 7 & \beta \\ 1 & 5 & 5 \end{vmatrix} = 0 \Rightarrow 13 - \beta = 0 \Rightarrow \beta = 13$

Also for $\alpha = -3$ and $\beta = 13$ $\Delta_x = \Delta_y = 0$

$\therefore \alpha + \beta = -3 + 13 = 10$

16. The integral $\int \frac{dx}{(x+4)^{\frac{7}{8}}(x-3)^{\frac{6}{7}}}$ is equal to :

(where C is a constant of integration)

(1) $\left(\frac{x-3}{x+4}\right)^{\frac{1}{7}} + C$

(2) $-\left(\frac{x-3}{x+4}\right)^{\frac{1}{7}} + C$

(3) $\frac{1}{2}\left(\frac{x-3}{x+4}\right)^{\frac{3}{7}} + C$

(4) $-\frac{1}{13}\left(\frac{x-3}{x+4}\right)^{\frac{13}{7}} + C$

NTA Ans. (1)

Sol. $f(x) = a + bx + cx^2$

$$\int_0^1 f(x)dx = \left[ax + \frac{bx^2}{2} + \frac{cx^3}{3} \right]_0^1$$

$$= a + \frac{b}{2} + \frac{c}{3} = \frac{1}{6}[6a + 3b + c]$$

$$= \frac{1}{6} \left[f(0) + f(1) + 4f\left(\frac{1}{2}\right) \right]$$

21. The coefficient of x^4 is the expansion of $(1 + x + x^2)^{10}$ is _____.

NTA Ans. (615.00)

Sol. $(1 + x + x^2)^{10}$

$$= {}^{10}C_0 + {}^{10}C_1x(1 + x) + {}^{10}C_2x^2(1 + x)^2 + {}^{10}C_3x^3(1 + x)^3 + {}^{10}C_4x^4(1 + x)^4 + \dots$$

$$\text{Coeff. of } x^4 = {}^{10}C_2 + {}^{10}C_3 \times {}^3C_1 + {}^{10}C_4 = 615.$$

22. The number of distinct solutions of the equation

$$\log_{\frac{1}{2}} |\sin x| = 2 - \log_{\frac{1}{2}} |\cos x| \text{ in the interval}$$

$[0, 2\pi]$, is _____.

NTA Ans. (8.00)

Sol. $\log_{1/2} |\sin x| = 2 - \log_{1/2} |\cos x|; x \in [0, 2\pi]$

$$\Rightarrow \log_{1/2} |\sin x| + \log_{1/2} |\cos x| = 2$$

$$\Rightarrow \log_{1/2} (|\sin x \cos x|) = 2$$

$$\Rightarrow |\sin x \cos x| = \frac{1}{4} \Rightarrow |\sin 2x| = \frac{1}{2}$$

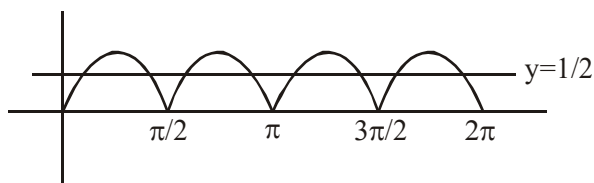

\Rightarrow 8 solutions

23. If for $x \geq 0$, $y = y(x)$ is the solution of the differential equation

$$(x + 1)dy = ((x + 1)^2 + y - 3)dx, y(2) = 0,$$

then $y(3)$ is equal to _____.

NTA Ans. (3.00)

Sol. $(x + 1)dy - ydx = ((x + 1)^2 - 3)dx$

$$\Rightarrow \frac{(x + 1)dy - ydx}{(x + 1)^2} = \left(1 - \frac{3}{(x + 1)^2} \right) dx$$

$$\Rightarrow d\left(\frac{y}{(x + 1)}\right) = \left(1 - \frac{3}{(x + 1)^2} \right) dx$$

integrating both sides

$$\frac{y}{x + 1} = x + \frac{3}{(x + 1)} + C$$

$$\text{Given } y(2) = 0 \Rightarrow c = -3$$

$$\therefore y = (x + 1) \left(x + \frac{3}{(x + 1)} - 3 \right)$$

$$\therefore y(3) = 3.00$$

24. If the vectors, $\vec{p} = (a + 1)\hat{i} + a\hat{j} + a\hat{k}$,

$$\vec{q} = a\hat{i} + (a + 1)\hat{j} + a\hat{k} \text{ and}$$

$$\vec{r} = a\hat{i} + a\hat{j} + (a + 1)\hat{k} \text{ (} a \in \mathbb{R} \text{) are coplanar}$$

and $3(\vec{p} \cdot \vec{q})^2 - \lambda |\vec{r} \times \vec{q}|^2 = 0$, then the value of λ is _____.

NTA Ans. (1.00)

Sol. $\vec{p} = (a+1)\hat{i} + a\hat{j} + a\hat{k}$,

$\vec{q} = a\hat{i} + (a+1)\hat{j} + a\hat{k}$ and

$\vec{r} = a\hat{i} + a\hat{j} + (a+1)\hat{k}$

$\therefore \vec{p}, \vec{q}, \vec{r}$ are coplanar

$\Rightarrow [\vec{p} \ \vec{q} \ \vec{r}] = 0$

$\Rightarrow \begin{vmatrix} a+1 & a & a \\ a & a+1 & a \\ a & a & a+1 \end{vmatrix} = 0$

$\Rightarrow 3a + 1 = 0 \quad \Rightarrow a = -\frac{1}{3}$

$\vec{p} \cdot \vec{q} = -\frac{1}{3}, \quad \vec{r} \cdot \vec{q} = -\frac{1}{3}$

$|\vec{r}|^2 = |\vec{q}|^2 = \frac{2}{3}$

$\therefore 3(\vec{p} \cdot \vec{q})^2 - \lambda |\vec{r} \times \vec{q}|^2 = 0$

$\Rightarrow \lambda = \frac{3(\vec{p} \cdot \vec{q})^2}{|\vec{r} \times \vec{q}|^2} = \frac{3(\vec{p} \cdot \vec{q})^2}{|\vec{r}|^2 |\vec{q}|^2 - (\vec{r} \cdot \vec{q})^2} = 1.00$

25. The projection of the line segment joining the points $(1, -1, 3)$ and $(2, -4, 11)$ on the line joining the points $(-1, 2, 3)$ and $(3, -2, 10)$ is _____.

NTA Ans. (8.00)

Sol.

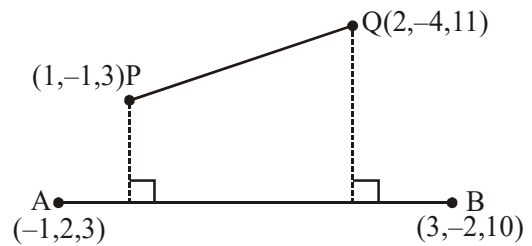

Projection of \overline{PQ} on $\overline{AB} = \frac{|\overline{PQ} \cdot \overline{AB}|}{|\overline{AB}|}$

$= \frac{|(\hat{i} - 3\hat{j} + 8\hat{k}) \cdot (4\hat{i} - 4\hat{j} + 7\hat{k})|}{9} = 8$