

20-05-2019**NEET-2019****CODE - 01**

Time : 3 :00 Hrs. समय : 3 घंटे

Max. Marks (अधिकतम अंक): 720

READ THE INSTRUCTIONS CAREFULLY (कृपया इन निर्देशों को ध्यान से पढ़ें)

Important Instructions:	महत्वपूर्ण निर्देश :
1. The Answer Sheet is inside this Test Booklet. When you are directed to open the Test Booklet, take out the Answer Sheet and fill in the particulars on Side-1 and Side-2 carefully with blue/black ball point pen only.	1. उत्तर पत्र इस परीक्षा पुस्तिका के अन्दर रखा है। जब आपको परीक्षा पुस्तिका खोलने को कहा जाए, तो उत्तर पत्र निकाल कर पृष्ठ-1 एवं पृष्ठ-2 पर केवल नीले/काले बॉल पॉइंट पेन से विवरण भरें।
2. The test is of 3 hours duration and Test Booklet contains 180 questions . Each question carries 4 marks . For each correct response, the candidate will get 4 marks . For each incorrect response, one mark will be deducted from the total scores. The maximum marks are 720 .	2. परीक्षा की अवधि 3 घंटे है एवं परीक्षा पुस्तिका में 180 प्रश्न हैं। प्रत्येक प्रश्न 4 अंक का है। प्रत्येक सही उत्तर के लिए परीक्षार्थी को 4 अंक दिए जाएंगे। प्रत्येक गलत उत्तर के लिए कुल योग में से एक अंक घटाया जाएगा। अधिकतम अंक 720 हैं।
3. Use Blue/Black Ball Point Pen only for writing particulars on this page/marking response.	3. इस पृष्ठ पर विवरण अंकित करने एवं उत्तर पत्र पर निशान लगाने के लिए केवल नीले/काले बॉल पॉइंट पेन का प्रयोग करें।
4. Rough work is to be done on the space provided for this purpose in the Test Booklet only.	4. रफ कार्य इस परीक्षा पुस्तिका में निर्धारित स्थान पर ही करें।
5. On completion of the test, the candidate must handover the Answer Sheet to the invigilator in the Room/Hall. The candidates are allowed to take away this Test Booklet with them.	5. परीक्षा सम्पन्न होने पर, परीक्षार्थी कक्ष/हॉल छोड़ने से पूर्व उत्तर पत्र कक्ष निरीक्षक को अवश्य सौंप दें। परीक्षार्थी अपने साथ प्रश्न पुस्तिका को ले जा सकते हैं।
6. The CODE for this Booklet is W . Make sure that the CODE printed on Side-2 of the Answer Sheet is the same as that on this Booklet. In case of discrepancy, the candidate should immediately report the matter to the invigilator for replacement of both the Test Booklets and the Answer Sheets.	6. इस पुस्तिका का संकेत है W . यह सुनिश्चित कर लें कि इस पुस्तिका का संकेत, उत्तर पत्र के पृष्ठ-2 पद छपे संकेत से मिलता है। अगर यह भिन्न हो, तो परीक्षार्थी दूसरी परीक्षा पुस्तिका और उत्तर पत्र लेने के लिए निरीक्षक को तुरन्त अवगत कराए।
7. The Candidates should ensure that the Answer Sheet is not folded. Do not make any stray marks on the Answer Sheet. Do not write your roll no. anywhere else except in the specified space in the Test Booklet/Answer Sheet.	7. परीक्षार्थी सुनिश्चित करें कि इस उत्तर पत्र को मोड़ा न जाए एवं उस पर कोई अन्य निशान न लगाएं। परीक्षार्थी अपना अनुक्रमांक प्रश्न पुस्तिका/उत्तर पत्र में निर्धारित स्थान के अतिरिक्त अन्यत्र न लिखें।
8. Use of white fluid for correction is NOT permissible on the Answer Sheet.	8. उत्तर पत्र पर किसी प्रकार के संशोधन हेतु व्हाइट फ्लूइड के प्रयोग की अनुमति नहीं है।

In case of any ambiguity in translation of any question, English version shall be treated as final.

प्रश्नों के अनुवाद में किसी अस्पष्टता की स्थिति में, अंग्रेजी संस्करण को ही अन्तिम माना जायेगा।

Name of the Candidate (in Capital letters) : _____

Roll Number : in figures : in words : _____

Name of Examination Centre (in Capital letters) : _____

Candidate's Signature : _____ Invigilator's Signature : _____

PART - A (BIOLOGY)

1. Which of the following cell organelles is present in the highest number in secretory cells?

- (1) Mitochondria (2) Golgi complex
(3) Endoplasmic reticulum (4) Lysosomes

Ans (2)

2. Non-membranous nucleoplasmic structures in nucleus are the site for active synthesis of

- (1) protein synthesis (2) mRNA (3) rRNA (4) tRNA

Ans (3)

3. Which of the following nucleic acids is present in an organism having 70 S ribosomes only?

- (1) Single stranded DNA with protein coat
(2) Double stranded circular naked DNA
(3) Double stranded DNA enclosed in nuclear membrane
(4) Double stranded circular DNA with histone proteins

Ans (2)

4. After meiosis I, the resultant daughter cells have

- (1) same amount of DNA as in the parent cell in S phase.
(2) twice the amount of DNA in comparison to haploid gamete.
(3) same amount of DNA in comparison to haploid gamete
(4) four times the amount of DNA in comparison to haploid gamete

Ans (2)

5. Which of the following organic compounds is the main constituent of Lecithin?

- (1) Arachidonic acid (2) Phospholipid (3) Cholesterol (4) Phosphoprotein

Ans (2)

6. The main difference between active and passive transport across cell membrane is :

- (1) passive transport is non-selective whereas active transport is selective.
(2) passive transport requires a concentration gradient across a biological membrane whereas active transport requires energy to move solutes.
(3) passive transport is confined to anionic carrier proteins whereas active transport is confined to cationic channel proteins.
(4) active transport occurs more rapidly than passive transport.

Ans (2)

7. Match the items given in Column - I with those in Column - II and choose the correct option.

	Column-I		Column-II
(a)	Rennin	(i)	Vitamin B ₁₂
(b)	Enterokinase	(ii)	Facilitated transport
(c)	Oxyntic cells	(iii)	Milk proteins
(d)	Fructose	(iv)	Trypsinogen

- (1) (a) - (iii), (b)- (iv), (c)- (ii), (d)-(i)
(2) (a) - (iv), (b)- (iii), (c)- (i), (d)-(ii)
(3) (a) - (iv), (b)- (iii), (c)- (ii), (d)-(i)
(4) (a) - (iii), (b)- (iv), (c)- (i), (d)-(ii)

Ans (4)

8. Kwashiorkor disease is due to
 (1) simultaneous deficiency of proteins and fats
 (2) simultaneous deficiency of proteins and calories
 (3) deficiency of carbohydrates
 (4) protein deficiency not accompanied by calorie deficiency

Ans (2)

9. Select the correct sequence of events.
 (1) Gametogenesis → Gamete transfer → Syngamy → Zygote → Cell division (Cleavage) → Cell differentiation → Organogenesis
 (2) Gametogenesis → Gamete transfer → Syngamy → Zygote → Cell division (Cleavage) → Organogenesis → Cell differentiation
 (3) Gametogenesis → Syngamy → Gamete transfer → Zygote → Cell division (Cleavage) → Cell differentiation → Organogenesis
 (4) Gametogenesis → Gamete transfer → Syngamy → Zygote → Cell differentiation → Cell division (Cleavage) → Organogenesis

Ans (1)

10. Which of the following hormones is responsible for both the milk ejection reflex and the foetal ejection reflex?
 (1) Estrogen (2) Prolactin (3) Oxytocin (4) Relaxin

Ans (3)

11. No new follicles develop in the luteal phase of the menstrual cycle because :
 (1) Follicles do not remain in the ovary after ovulation.
 (2) FSH levels are high in the luteal phase
 (3) LH levels are high in the luteal phase
 (4) Both FSH and LH levels are low in the luteal phase

Ans (4)

12. In Australia, marsupials and placental mammals have evolved to share many similar characteristics. This type of evolution may be referred to as -
 (1) Adaptive Radiation (2) Divergent Evolution
 (3) Cyclical Evolution (4) Convergent Evolution

Ans (4)

13. Match the items of Column - I with Column - II :

	Column-I		Column-II
(a)	XX-XO method of sex determination	(i)	Turner's syndrome
(b)	XX-XY method of sex Determination	(ii)	Female heterogametic
(c)	Karyotype-45	(iii)	Grasshopper
(d)	ZW-ZZ method of Sex Determination	(iv)	Female homogametic

Select the correct option from the following:

- (1) (a) - (ii), (b)- (iv), (c)- (i), (d)-(iii)
 (2) (a) - (i), (b)- (iv), (c)- (ii), (d)-(iii)
 (3) (a) - (iii), (b)- (iv), (c)- (i), (d)-(ii)
 (4)(a) - (iv), (b)- (ii), (c)- (i), (d)-(iii)

Ans (3)

14. What will be the sequence of mRNA produced by the following stretch of DNA?
 3' ATGCATGCATGCATG 5' TEMPLATE STRAND
 5' TACGTACGTACGTAC 3' CODING STRAND
 (1) 3' AUGCAUGCAUGCAUG 5' (2) 5' UACGUACGUACGUAC 3'
 (3) 3' UACGUACGUACGUAC 5' (4) 5' AUGCAUGCAUGCAUG 3'

Ans (2)

15. **Select the incorrect statement regarding inbreeding.**
 (1) Inbreeding helps in elimination of deleterious alleles from the population.
 (2) Inbreeding is necessary to evolve a pure-line in any animal.
 (3) Continued inbreeding reduces fertility and leads to inbreeding depression.
 (4) Inbreeding depression can not be overcome by Out-crossing.

Ans (4)

16. A biocontrol agent to be a part of an integrated pest management should be
 (1) species-specific and symbiotic
 (2) free living and broad spectrum
 (3) narrow spectrum and symbiotic
 (4) species-specific and inactive on non-target organisms

Ans (4)

17. Match the following enzymes with their functions:

	Column-I		Column-II
(a)	Restriction endonuclease	(i)	joins the DNA fragments
(b)	Restriction exonuclease	(ii)	extends primers on genomic DNA template
(c)	DNA ligase	(iii)	cuts DNA at specific position
(d)	Tag polymerase	(iv)	removes nucleotides from the ends of DNA

Select the correct option from the following:

- (1) (a) - (iii), (b)- (i), (c)- (iv), (d)-(ii)
 (2) (a) - (iii), (b)- (iv), (c)- (i), (d)-(ii)
 (3) (a) - (iv), (b)- (iii), (c)- (i), (d)-(ii)
 (4) (a) - (ii), (b)- (iv), (c)- (i), (d)-(iii)

Ans (2)

18. The two antibiotic resistance genes on vector pBR 322 are for
 (1) Ampicillin and Tetracycline (2) Ampicillin and Chloramphenicol
 (3) Chloramphenicol and Tetracycline (4) Tetracycline and Kanamycin

Ans (1)

19. Exploitation of bioresources of a nation by multinational companies without authorization from the concerned country is referred to as
 (1) Bioweapon (2) Biopiracy (3) Bioethics (4) Biowar

Ans (2)

20. Carnivorous animals - lions and leopards, occupy the same niche but lions predate mostly larger animals and leopards take smaller ones. This mechanism of competition is referred to as -
- (1) Character displacement (2) Altruism
 (3) Resource partitioning (4) Competitive exclusion

Ans (3)

21. Decline in the population of Indian native fishes due to introduction of *Clarias gariepinus* in river Yamuna can be categorised as
- (1) Co-extinction (2) Habitat fragmentation
 (3) Over exploitation (4) Alien species invasion

Ans (4)

22. Match the following RNA polymerases with their transcribed products:

	Column-I		Column-II
(a)	RNA polymerase I	(i)	tRNA
(b)	RNA polymerase II	(ii)	rRNA
(c)	RNA polymerase III	(iii)	hnRNA

Select the correct option from the following:

- (1) (a)-(i), (b)-(iii), (c)-(ii)
 (2) (a)-(i), (b)-(ii), (c)-(iii)
 (3) (a)-(ii), (b)-(iii), (c)-(i)
 (4) (a)-(iii), (b)-(ii), (c)-(i)

Ans (3)

23. In a marriage between male with blood group A and female with blood group B, the progeny had either blood group AB or B. What could be the possible genotype of parents?
- (1) $I^A i$ (Male) ; $I^B I^B$ (Female) (2) $I^A I^A$ (Male) ; $I^B I^B$ (Female)
 (3) $I^A I^A$ (Male) ; $I^B i$ (Female) (4) $I^A i$ (Male) ; $I^B i$ (Female)

Ans (1)

24. A population of a species invades a new area. Which of the following condition will lead to Adaptive Radiation?
- (1) Area with large number of habitats having very low food supply.
 (2) Area with a single type of vacant habitat.
 (3) Area with many types of vacant habitats.
 (4) Area with many habitats occupied by a large number of species.

Ans (3)

25. Identify A, B and C in the diagrammatic representation of the mechanism of hormone action.

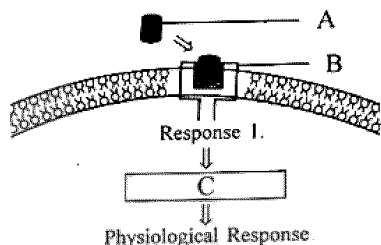

Select the correct option from the following:

- (1) A = Steroid Hormone; B = Hormone receptor Complex; C = Protein
 (2) A = Protein Hormone; B = Receptor; C = Cyclic AMP
 (3) A = Steroid Hormone; B = Receptor; C = Second Messenger
 (4) A = Protein Hormone; B = Cyclic AMP; C = Hormone-receptor Complex

Ans (2)

26. Humans have acquired immune system that produces antibodies to neutralize pathogens. Still innate immune system is present at the time of birth because it
- (1) is very specific and uses different macrophages,
 - (2) produces memory cells for mounting fast secondary response.
 - (3) has natural killer cells which can phagocytose and destroy microbes
 - (4) provides passive immunity.

Ans (3)

27. Which of the following statements is not correct?
- (1) An action potential in an axon does not move backward because the segment behind is in a refractory phase.
 - (2) Depolarization of hair cells of cochlea results in the opening of the mechanically gated Potassium-ion channels.
 - (3) Rods are very sensitive and contribute to daylight vision.
 - (4) In the knee-jerk reflex, stimulus is the stretching of muscle and response is its contraction.

Ans (3)

28. Match the following joints with the bones involved:

	Column-I		Column-II
(a)	Gliding joint	(i)	Between carpal and metacarpal of thumb
(b)	Hinge joint	(ii)	Between Atlas and Axis
(c)	Pivot joint	(iii)	Between the Carpals
(d)	Saddle joint	iv	Between Humerus and Ulna

Select the correct option from the following:

- (1) (a)-(iii), (b)-(iv), (c)-(ii), (d)-(i)
- (2) (a)-(iv), (b)-(i), (c)-(ii), (d)-(iii)
- (3) (a)-(iv), (b)-(ii), (c)-(iii), (d)-i
- (4) (a)-(i), (b)-(iii), (c)-(ii), (d)-(iv)

Ans (1)

29. Which of the following diseases is an auto-immune disorder

- (1) Myasthenia gravis
- (2) Arthritis
- (3) Osteoporosis
- (4) Gout

Ans (1)

30. Artificial light, extended work-time and reduced sleep-time disrupt the activity of

- (1) Thymus gland
- (2) Pineal gland
- (3) Adrenal gland
- (4) Posterior pituitary gland

Ans (2)

31. Which of the following conditions will stimulate parathyroid gland to release parathyroid hormone ?

- (1) Fall in active Vitamin D levels
- (2) Fall in blood Ca^{+2} levels
- (3) Fall in bone Ca^{+2} levels
- (4) Rise in blood Ca^{+2} levels

Ans (2)

32. Which of the following is a correct statement ?

- (1) IUDs once inserted need not be replaced.
- (2) IUDs are generally inserted by the user herself.
- (3) IUDs increase phagocytosis of sperms in the uterus.
- (4) IUDs suppress gametogenesis.

Ans (3)

33. Which of the following sexually transmitted diseases do not specifically affect reproductive organs ?

- (1) Genital warts and Hepatitis-B
- (2) Syphilis and Genital herpes
- (3) AIDS and Hepatitis B
- (4) Chlamydiasis and AIDS

Ans (3)

34. Match the following genera with their respective phylum :

- | | |
|--------------|----------------------|
| (a) Ophiura | (i) Mollusca |
| (b) Physalia | (ii) Platyhelminthes |
| (c) Pinctada | (iii) Echinodermata |
| (d) Planaria | (iv) Coelenterata |

Select the correct option :

- (1) (a)-(iv), (b)-(i), (c)-(iii), (d)-(ii)
- (2) (a)-(iii), (b)-(iv), (c)-(i), (d)-(ii)
- (3) (a)-(i), (b)-(iii), (c)-(iv), (d)-(ii)
- (4) (a)-(iii), (b)-(iv), (c)-(ii), (d)-(i)

Ans (2)

35. Which of the following animals are true coelomates with bilateral symmetry ?

- (1) Adult Echinoderms
- (2) Aschelminthes
- (3) Platyhelminthes
- (4) Annelids

Ans (4)

36. The contrasting characteristics generally in a pair used for identification of animals in Taxonomic Key are referred to as :

- (1) Lead
- (2) Couplet
- (3) Doublet
- (4) Alternate

Ans (2)

37. Match the following cell structure with its characteristic feature :

- | | |
|------------------------|---|
| (a) Tight junctions | (i) Cement neighbouring cells together to form sheet |
| (b) Adhering junctions | (ii) Transmit information through chemical to another cells |
| (c) Gap junctions | (iii) Establish a barrier to prevent leakage of fluid across epithelial cells |
| (d) Synaptic junctions | (iv) Cytoplasmic channels to facilitate communication between adjacent cells |

Select correct option from the following :

- (1) (a)-(ii), (b)-(iv), (c)-(i), (d)-(iii)
- (2) (a)-(iv), (b)-(ii), (c)-(i), (d)-(iii)
- (3) (a)-(iii), (b)-(i), (c)-(iv), (d)-(ii)
- (4) (a)-(iv), (b)-(iii), (c)-(i), (d)-(ii)

Ans (3)

38. Which of the following statements is INCORRECT ?
- (1) Cockroaches exhibit mosaic vision with less sensitivity and more resolution
 - (2) A mushroom-shaped gland is present in the 6th-7th abdominal segments of male cockroach.
 - (3) A pair of spermatheca is present in the 6th segment of female cockroach
 - (4) Female cockroach possesses sixteen ovarioles in the ovaries.

Ans (1)

39. Select the correct statement.
- (1) Expiration occurs due to external intercostal muscles.
 - (2) Intrapulmonary pressure is lower than the atmospheric pressure during inspiration.
 - (3) Inspiration occurs when atmospheric pressure is less than intrapulmonary pressure.
 - (4) Expiration is initiated due to contraction of diaphragm.

Ans (2)

40. The maximum volume of air a person can breathe in after a forced expiration is known as :
- (1) Expiratory Capacity
 - (2) Vital Capacity
 - (3) Inspiratory Capacity
 - (4) Total Lung Capacity

Ans (2)

41. All the components of the nodal tissue are autoexcitable. Why does the SA node act as the normal pacemaker ?
- (1) SA node has the lowest rate of depolarisation.
 - (2) SA node is the only component to generate the threshold potential.
 - (3) Only SA node can convey the action potential to the other components.
 - (4) SA node has the highest rate of depolarisation.

Ans (4)

42. A specialised nodal tissue embedded in the lower corner of the right atrium, close to Atrio-ventricular septum, delays the spreading of impulses to heart apex for about 0.1 sec. This delay allows -
- (1) blood to enter aorta.
 - (2) the ventricles to empty completely.
 - (3) blood to enter pulmonary arteries.
 - (4) the atria to empty completely.

Ans (4)

43. Match the following parts of a nephron with their function:
- | | |
|-------------------------------------|---|
| (a) Descending limb of Henle's loop | (i) Reabsorption of salts only |
| (b) Proximal convoluted tubule | (ii) Reabsorption of water only |
| (c) Ascending limb of Henle's loop | (iii) Conditional reabsorption of sodium ions and water |
| (d) Distal convoluted tubule | (iv) Reabsorption of ions, water and organic nutrients |

Select the correct option from the following :

- (1) (a)-(i), (b)-(iii), (c)-(ii), (d)-(iv)
- (2) (a)-(ii), (b)-(iv), (c)-(i), (d)-(iii)
- (3) (a)-(i), (b)-(iv), (c)-(ii), (d)-(iii)
- (4) (a)-(iv), (b)-(i), (c)-(iii), (d)-(ii)

Ans (2)

44. Match the items in Column - I with those in Column - II :

Column - I	Column - II
(a) Podocytes	(i) Crystallised oxalates
(b) Protonephridia	(ii) Annelids
(c) Nephridia	(iii) Amphioxus
(d) Renal calculi	(iv) Filtration slits

Select the correct option from the following:

- (1) (a)-(iii), (b)-(iv), (c)-(ii), (d)-(i)
- (2) (a)-(iii), (b)-(ii), (c)-(iv), (d)-(i)
- (3) (a)-(iv), (b)-(iii), (c)-(ii), (d)-(i)
- (4) (a)-(iv), (b)-(ii), (c)-(iii), (d)-(i)

Ans (3)

45. Which of the following receptors are specifically responsible for maintenance of balance of body and posture ?

- (1) Basilar membrane and otoliths
- (2) Hair cells and organ of corti
- (3) Tectorial membrane and macula
- (4) Crista ampullaris and macula

Ans (4)

46. Which of the following is against the rules of ICBN?

- (1) Hand written scientific names should be underlined.
- (2) Every species should have a generic name and a specific epithet.
- (3) Scientific names are in Latin and should be italicized.
- (4) Generic and specific names should be written starting with small letters.

Ans (4)

47. Mad cow disease in cattle is caused by an organism which has :

- (1) Inert crystalline
- (2) Abnormally folded protein
- (3) Free RNA without protein coat
- (4) Free DNA without protein coat

Ans (2)

48. Which of the following statements is correct?

- (1) Lichens do not grow in polluted areas.
- (2) Algal component of lichens is called mycobiont.
- (3) Fungal component of lichens is called phycobiont.
- (4) Lichens are not good pollution indicators.

Ans (1)

49. Match the organisms in column I with habitats in column II.

Column I	Column II
(a) Halophiles	(i) Hot springs
(b) Thermoacidophiles	(ii) Aquatic environment
(c) Methanogens	(iii) Guts of ruminants
(d) Cyanobacteria	(iv) Salty areas

Select the correct answer from the options given below :

- (1) (a)-(iv), (b)-(i), (c)-(iii), (d)-(ii)
- (2) (a)-(i), (b)-(ii), (c)-(iii), (d)-(iv)
- (3) (a)-(iii), (b)-(iv), (c)-(i), (d)-(i)
- (4) (a)-(ii), (b)-(iv), (c)-(iii), (d)-(i)

Ans (1)

50. In the dicot root the vascular cambium originates from :
- (1) Tissue located below the phloem bundles and a portion of pericycle tissue above protoxylem.
 - (2) Cortical region
 - (3) Parenchyma between endodermis and pericycle
 - (4) Intrafascicular and interfascicular tissue in a ring

Ans (1)

51. Which of the following shows whorled phyllotaxy ?
- (1) Mustard
 - (2) China rose
 - (3) Alstonia
 - (4) Calotropis <http://www.xamstudy.com>

Ans (3)

52. Regeneration of damaged growing grass following grazing is largely due to :
- (1) Lateral meristem
 - (2) Apical meristem
 - (3) Intercalary meristem
 - (4) Secondary meristem

Ans (3)

53. Bicarpellary ovary with obliquely placed septum is seen in :
- (1) Brassica
 - (2) Aloe
 - (3) Solanum
 - (4) Sesbania

Ans (3)

54. Which is the most common type of embryo sac in angiosperms?
- (1) Tetrasporic with one mitotic stage of divisions
 - (2) Monosporic with three sequential mitotic divisions
 - (3) Monosporic with two sequential mitotic divisions
 - (4) Bisporic with two sequential mitotic divisions

Ans (2)

55. From the following, identify the correct combination of salient features of Genetic Code
- (1) Universal, Non-ambiguous, Overlapping
 - (2) Degenerate, Overlapping, Commaless
 - (3) Universal, Ambiguous, Degenerate
 - (4) Degenerate, Non-overlapping, Non ambiguous

Ans (4)

56. Which scientist experimentally proved that DNA is the sole genetic material in bacteriophage ?
- (1) Beadle and Tatum
 - (2) Messelson and Stahl
 - (3) Hershey and Chase
 - (4) Jacob and Monod

Ans (3)

57. In the process of transcription in Eukaryotes, the RNA polymerase I transcribes -
(1) mRNA with additional processing, capping and tailing
(2) tRNA, 5 S rRNA and snRNAs
(3) rRNAs - 28 S, 18 S and 5.8 S
(4) Precursor of mRNA, hnRNA

Ans (3)

58. In which genetic condition, each cell in the affected person, has three sex chromosomes XXY?
(1) Thalassemia
(2) Klinefelter's Syndrome
(3) Phenylketonuria
(4) Turner's Syndrome

Ans (2)

59. What initiation and termination factors are involved in transcription in Eukaryotes ?
(1) σ and ρ , respectively
(2) α and β , respectively
(3) β and γ , respectively
(4) α and σ , respectively

Ans (1/bonus)

60. Which of the following statements is correct about the origin and evolution of men ?
(1) Agriculture came around 50,000 years back.
(2) The Dryopithecus and Ramapithecus primates existing 15 million years ago, walked like men.
(3) Homo habilis probably ate meat.
(4) Neanderthal men lived in Asia between 100000 and 40000 years back

Ans (4)

61. The production of gametes by the parents the formation of zygotes, the F_1 and F_2 plants can be understood using
(1) Pie diagram
(2) A pyramid diagram
(3) Punnet square
(4) Wenn diagram

Ans (3)

62. Match the column I with column II.

Column I

Column II

- | | |
|---------------------|--|
| (a) Golgi apparatus | (i) Synthesis of protein |
| (b) Lysosomes | (ii) Trap waste and excretory products |
| (c) Vacuoles | (iii) Formation of glycoproteins and glycolipids |
| (d) Ribosomes | (iv) Digesting biomolecules |

Choose the right match from options given below:

- (1) (a)-(iii), (b)-(iv), (c)-(ii), (d)-(i)
(2) (a)-(iv), (b)-(iii), (c)-(i), (d)-(ii)
(3) (a)-(iii), (b)-(ii), (c)-(iv), (d)-(i)
(4) (a)-(i), (b)-(ii), (c)-(iv), (d)-(iii)

Ans (1)

63. Prosthetic groups differ from co-enzymes in that,
(1) they require metal ions for their activity.
(2) they (prosthetic groups) are tightly bound to apoenzymes.
(3) their association with apoenzymes is transient.
(4) they can serve as co-factors in a number of enzyme-catalyzed reactions.
- Ans (2)**
64. Crossing over takes place between which chromatids and in which stage of the cell cycle?
(1) Non-sister chromatids of non-homologous chromosomes at Zygotene stage of prophase I.
(2) Non-sister chromatids of homologous chromosomes at Pachytene stage of prophase I.
(3) Non-sister chromatids of homologous chromosomes at Zygotene stage of prophase I.
(4) Non-sister chromatids of non-homologous chromosomes at Pachytene stage of prophase I.
- Ans (2)**
65. "Ramachandran plot" is used to confirm the structure of
(1) RNA
(2) Proteins
(3) Triacylglycerides
(4) DNA
- Ans (2)**
66. Which of the following is not a feature of active transport of solutes in plants ? .
(1) Occurs against concentration gradient
(2) Non-selective
(3) Occurs through membranes
(4) Requires ATP
- Ans (2)**
67. Which of the following bacteria reduce nitrate in soil into nitrogen ?
(1) Nitrobacter
(2) Thiobacillus
(3) Nitrococcus
(4) Nitrosomonas
- Ans (3)**
68. What will be the direction of flow of water when a plant cell is placed in a Hypotonic solution?
(1) Water will flow in both directions.
(2) Water will flow out of the cell.
(3) Water will flow into the cell.
(4) No flow of water in any direction.
- Ans (3)**
69. Where is the respiratory electron transport system (ETS) located in plants?
(1) Mitochondrial matrix
(2) Outer mitochondrial membrane
(3) Inner mitochondrial membrane
(4) Intermembrane space
- Ans (3)**

70. In Hatch and Slack pathway, the primary CO₂ acceptor is -

- (1) Oxaloacetic acid
- (2) Phosphoglyceric acid
- (3) Phosphoenol pyruvate
- (4) Rubisco

Ans (3)

71. Removal of shoot tips is a very useful technique to boost the production of tea-leaves. This is because

- (1) Gibberellins prevent bolting and are inactivated.
- (2) Auxins prevent leaf drop at early stages.
- (3) Effect of auxins is removed and growth of lateral buds is enhanced.
- (4) Gibberellins delay senescence of leaves.

Ans (3)

72. One scientist cultured *Cladophora* in a suspension of *Azotobacter* and illuminated the culture by splitting light through a prism. He observed that bacteria accumulated mainly in the region of :

- (1) Violet and green light
- (2) Indigo and green light
- (3) Orange and yellow light
- (4) Blue and red light

Ans (4)

73. In order to increase the yield of sugarcane crop, which of the following plant growth regulators should be sprayed ?

- (1) Ethylene
- (2) Auxins
- (3) Gibberellins
- (4) Cytokinins

Ans (3)

74. What type of pollination takes place in *Vallisneria* ?

- (1) Pollination occurs in submerged condition by water.
- (2) Flowers emerge above surface of Water and pollination occurs by insects.
- (3) Flowers emerge above water surface and pollen is carried by wind.
- (4) Male flowers are carried by water currents to female flowers at surface of water.

Ans (4)

75. In which one of the following, both autogamy and geitonogamy are prevented?

- (1) Wheat
- (2) Papaya
- (3) Castor
- (4) Maize

Ans (2)

76. Match the placental types (column-I) with their examples (column-II)

Column-I

Column-II

- | | |
|------------------|-----------------|
| (a) Basal | (i) Mustard |
| (b) Axile | (ii) China rose |
| (c) Parietal | (iii) Dianthus |
| (d) Free central | (iv) Sunflower |

Choose the correct answer from the following options:

- (1) (a)-(ii), (b)-(iii), (c)-(iv), (d)-(i)
- (2) (a)-(i), (b)-(ii), (c)-(iii), (d)-(iv)
- (3) (a)-(iv), (b)-(ii), (c)-(i), (d)-(iii)
- (4) (a)-(iii), (b)-(iv), (c)-(i), (d)-(ii)

Ans (3)

77. A selectable marker is used to :
- (1) help in eliminating the non transformants so that the transformants can be regenerated
 - (2) identify the gene for a desired trait in an alien organism
 - (3) select a suitable vector for transformation in a specific crop
 - (4) mark a gene on a chromosome for isolation using restriction enzyme
- Ans (1)**
78. Western Ghats have a large number of plant and animal species that are not found anywhere else. Which of the following terms will you use to notify such species ?
- (1) Endemic
 - (2) Vulnerable
 - (3) Threatened
 - (4) Keystone
- Ans (1)**
79. Which of the following statements about ozone is correct ?
- (1) Tropospheric ozone protects us from UV radiations.
 - (2) Stratospheric ozone is 'bad'.
 - (3) Tropospheric ozone is 'good'.
 - (4) Stratospheric ozone protects us from UV radiations.
- Ans (4)**
80. Exploration of molecular, genetic and species level diversity for novel products of economic importance is known as :
- (1) Biopiracy
 - (2) Bioenergetics
 - (3) Bioremediation
 - (4) Bioprospecting
- Ans (4)**
81. Which of the following is an innovative remedy for plastic waste ?
- (1) Burning in the absence of oxygen
 - (2) Burying 500 m deep below soil surface
 - (3) Polyblend
 - (4) Electrostatic precipitator
- Ans (3)**
82. Between which among the following, the relationship is not an example of commensalism ?
- (1) Orchid and the tree on which it grows
 - (2) Cattle Egret and grazing cattle
 - (3) Sea Anemone and Clown fish
 - (4) Female wasp and fig species
- Ans (4)**
83. If an agricultural field is liberally, irrigated for a prolonged period of time, it is likely to face a problem of :
- (1) Metal toxicity
 - (2) Alkalinity
 - (3) Acidity
 - (4) Salinity
- Ans (3)**

84. Which of the following statements about methanogens is not correct?

- (1) They can be used to produce biogas,
- (2) They are found in the rumen of cattle and their excreta.
- (3) They grow aerobically and breakdown cellulose-rich food.
- (4) They produce methane gas.

Ans (3)

85. In mung bean, resistance to yellow mosaic, virus and powdery mildew were brought about by :

- (1) Mutation breeding
- (2) Biofortification
- (3) Tissue culture
- (4) Hybridization and selection

Ans (1)

86. Coca alkaloid or cocaine is obtained from

- (1) *Papaver somniferum*
- (2) *Atropa belladonna*
- (3) *Erythroxylum coca*
- (4) *Datura*

Ans (3)

87. Among the following pairs of microbes, which pair has both the microbes that can be used as biofertilizers ?

- (1) *Aspergillus* and *Rhizopus*
- (2) *Rhizobium* and *Rhizopus*
- (3) *Cyanobacteria* and *Rhizobium*
- (4) *Aspergillus* and *Cyanobacteria*

Ans (3)

88. Given below are four statements pertaining to separation of DNA fragments using Gel electrophoresis. Identify the incorrect statements.

- (a) DNA is negatively charged molecule and so it is loaded on gel towards the Anode terminal.
- (b) DNA fragments travel along the surface of the gel whose concentration does not affect movement of DNA.
- (c) Smaller the size of DNA fragment, larger is the distance it travels through it.
- (d) Pure DNA can be visualized directly by exposing to UV radiation.

Choose correct answer from the options given below:

- (1) (a), (c) and (d)
- (2) (a), (b) and (c)
- (3) (b), (c) and (d)
- (4) (a), (b) and (d)

Ans (4)

89. An enzyme catalysing the removal of nucleotides from ends of DNA is :

- (1) DNA ligase
- (2) Endonuclease
- (2) Exonuclease
- (4) Protease

Ans (3)

90. In RNAi, the genes are silenced using :

- (1) ds – RNA
- (2) ss - DNA
- (3) ss – RNA
- (4) ds – DNA

Ans (1)

PART - B (CHEMISTRY)

91. The reaction that does not give benzoic acid as the major product is -

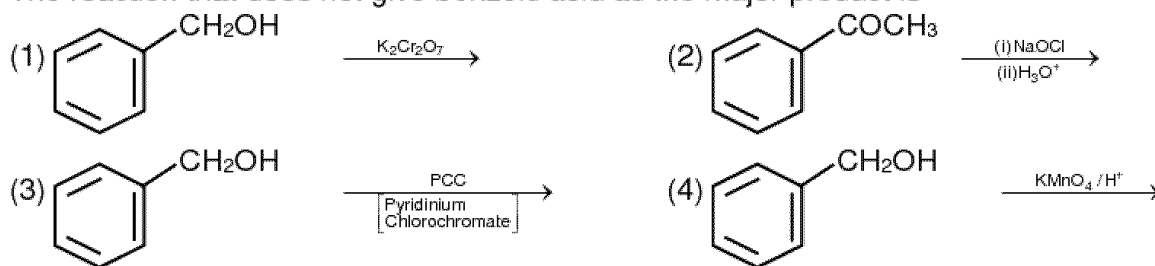

Ans. (3)

92. The amine that reacts with Hinsberg's reagent to give an alkali insoluble product is -



Ans. (1)

93. Which structure(s) of proteins remains(s) intact during denaturation process ?

- (1) Both secondary and tertiary structures (2) Primary structure only
(3) Secondary structure only (4) Tertiary structure only

Ans. (2)

Sol. T

94. The polymer that is used as a substitute for wool in making commercial fibers is -

- (1) melamine (2) nylon-6, 6
(3) Polyacrylonitrile (4) Buna - N

Ans. (3)

95. The artificial sweetner stable at cooking temperature and does not provide calories is -

- (1) Saccharin (2) Aspartame
(3) Sucralose (4) Alitame

Ans. (3)

96. The liquefied gas that is used in dry cleaning along with a suitable detergent is -

- (1) Water gas (2) Petroleum gas
(3) NO_2 (4) CO_2

Ans. (2)

Sol. T

97. The hydrolysis reaction that takes place at the slowest rate. among the following is

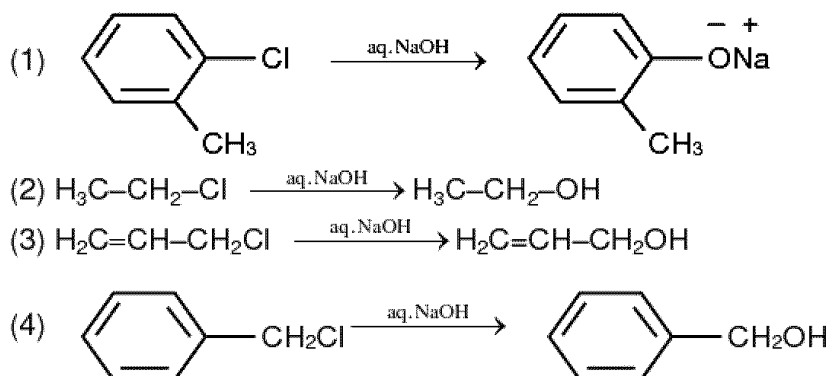

Ans. (1)

98. When vapour of a secondary alcohol is passed over heated copper at 573 K, the product formed is
 (1) a carboxylic acid (2) an aldehyde
 (3) a ketone (4) an alkene

Ans. (3)

99. The major product C and D formed in the following reaction respectively are :

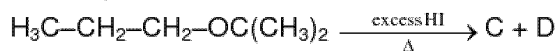

- (1) $\text{H}_3\text{C}-\text{CH}_2-\text{CH}_2-\text{I}$ and $\text{I}-\text{C}(\text{CH}_3)_3$ (2) $\text{H}_3\text{C}-\text{CH}_2-\text{CH}_2-\text{OH}$ and $\text{I}-\text{C}(\text{CH}_3)_3$
 (3) $\text{H}_3\text{C}-\text{CH}_2-\text{CH}_2-\text{I}$ and $\text{HO}-\text{C}(\text{CH}_3)_3$ (4) $\text{H}_3\text{C}-\text{CH}_2-\text{CH}_2-\text{OH}$ and $\text{HO}-\text{C}(\text{CH}_3)_3$

Ans. (1)

100. Match the oxide given in column A with its property given column-II

Column - I	Column-II
(i) Na_2O	(a) Neutral
(ii) Al_2O_3	(b) Basic
(iii) N_2O	(c) Acidic
(iv) Cl_2O_7	(d) Amphoteric

Which of the following options has all correct pairs ?

- (1) (i)-(b), (ii)-(a), (iii)-(d), (iv)-(c) (2) (i)-(c), (ii)-(b), (iii)-(a), (iv)-(d)
 (3) (i)-(a), (ii)-(d), (iii)-(b), (iv)-(c) (4) (i)-(b), (ii)-(d), (iii)-(a), (iv)-(c)

Ans. (4)

101. Match the catalyst with the process :

Catalys	Process
(i) V_2O_5	(a) The oxidation of ethyne to ethanal
(ii) $\text{TiCl}_4 + \text{Al}(\text{CH}_3)_3$	(b) Polymerisation
(iii) PdCl_2	(c) Oxidation of SO_2 in the manufacture of H_2SO_4
(iv) Nickel complexes	(d) Polymerisation of ethylene

- (1) (i)-(c), (ii)-(d), (iii)-(a), (iv)-(b) (2) (i)-(a), (ii)-(b), (iii)-(c), (iv)-(d)
 (3) (i)-(a), (ii)-(c), (iii)-(b), (iv)-(d) (4) (i)-(c), (ii)-(a), (iii)-(d), (iv)-(b)

Ans. (1)

102. The most stable carbocation among the following is

- (1) $(\text{CH}_3)_3\text{C}-\text{CH}^+-\text{CH}_3$ (2) $\text{CH}_3-\text{CH}_2-\text{CH}^+-\text{CH}_2-\text{CH}_3$
 (3) $\text{CH}_3-\text{CH}^+-\text{CH}_2-\text{CH}_2-\text{CH}_3$ (4) $\text{CH}_3-\text{CH}_2-\text{CH}^+$

Ans. (3)

103. The alkane that gives only one monochloro product on chlorination with Cl_2 in presence of diffused sunlight is -

- (1) 2,2,-dimethylbutane (2) neopentane
 (3) n-pentane (4) Isopentane

Ans. (2)

104. In the following reaction

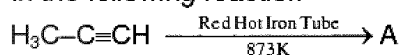

number of (σ) bond present in product (A) is -

- (1) 21 (2) 9 (3) 24 (4) 18

Ans. (1)

105. Aluminium chloride in acidified aqueous solution forms a complex 'A', in which hybridisation state of Al is 'B'. What are 'A' and 'B' respectively ?

- (1) $[\text{Al}(\text{H}_2\text{O})_6]^{3+}$, sp^3d^2 (2) $[\text{Al}(\text{H}_2\text{O})_4]^{3+}$, sp^3
 (3) $[\text{Al}(\text{H}_2\text{O})_4]^{3+}$, dsp^2 (4) $[\text{Al}(\text{H}_2\text{O})_6]^{3+}$, d^2sp^3

Ans. (1)

106. Which of the following compounds is used in cosmetic surgery ?

- (1) Silica (2) Silicates (3) Silicones (4) Zeolites

Ans. (3)

107. Identify the incorrect statement
 (1) The scientific and technological process used for isolation of the metal from its ore is known as metallurgy
 (2) Minerals are naturally occurring chemical substances in the earth's crust
 (3) Ores are minerals that may contain a metal
 (4) Gangue is an ore contaminated with undesired materials

Ans. (3)

108. A compound 'X' upon reaction with H_2O produces a colorless gas 'Y' with rotten fish smell. Gas 'Y' is absorbed in a solution of $CuSO_4$ to give Cu_3P_2 as one of the products. Predict the compound 'X'

- (1) Ca_3P_2 (2) NH_4Cl (3) As_2O_3 (4) $Ca_3(PO_4)_2$

Ans. (1)

109. Which of the following oxoacids of phosphorus has strongest reducing property ?

- (1) $H_4P_2O_7$ (2) H_3PO_3 (3) H_3PO_2 (4) H_3PO_4

Ans. (3)

Sol. T

110. Identify the correct formula of 'oleum' from the following

- (1) $H_2S_2O_7$ (2) H_2SO_3 (3) H_2SO_4 (4) $H_2S_2O_8$

Ans. (1)

111. When neutral or faintly alkaline $KMnO_4$ is treated with potassium iodide, iodide ion is converted into 'X', 'X' is -

- (1) I_2 (2) IO_4^- (3) IO_3^- (4) IO^-

Ans. (3)

112. The crystal field stabilization energy (CFSE) for $[CoCl_6]^{4-}$ is 18000 cm^{-1} , the CFSE for $[CoCl_4]^{2-}$ will be

- (1) 6000 cm^{-1} (2) 16000 cm^{-1} (3) 18000 cm^{-1} (4) 8000 cm^{-1}

Ans. (4)

113. following limiting molar conductivities are given as

$$\lambda_m^0(H_2SO_4) = x\text{ Scm}^2\text{ mol}^{-1}$$

$$\lambda_m^0(K_2SO_4) = y\text{ Scm}^2\text{ mol}^{-1}$$

$$\lambda_m^0(CH_3COOK) = z\text{ Scm}^2\text{ mol}^{-1}$$

$$\lambda_m^0(\text{in Scm}^2\text{ mol}^{-1}) \text{ for } CH_3COOH \text{ will be -}$$

- (1) $x - y + 2z$ (2) $x + y + z$ (3) $x - y + z$ (4) $\frac{(x - y)}{2} + z$

Ans. (3)

114. A first order reaction has a rate constant of $2.303 \times 10^{-3}\text{ s}^{-1}$. The time required for 40 g of this reactant to reduce to 10 g will be - [Given that $\log_{10} 2 = 0.3010$]

- (1) 230.3 s (2) 301 s (3) 2000 s (4) 602 s

Ans. (4)

115. For a reaction, activation energy $E_a = 0$ and the rate constant at 200 K is $1.6 \times 10^6\text{ s}^{-1}$. The rate constant at 400 K will be - [Given that gas constant, $R = 8.314\text{ J K}^{-1}\text{ mol}^{-1}$]

- (1) $3.2 \times 10^4\text{ s}^{-1}$ (2) $1.6 \times 10^6\text{ s}^{-1}$
 (3) $1.6 \times 10^3\text{ s}^{-1}$ (4) $3.2 \times 10^6\text{ s}^{-1}$

Ans. (2)

Sol. T

116. The correct option representing a Freundlich adsorption isotherm is -

- (1) $\frac{x}{m} = kp^{0.3}$ (2) $\frac{x}{m} = kp^{2.5}$
 (3) $\frac{x}{m} = kp^{-0.5}$ (4) $\frac{x}{m} = kp^{-1}$

Ans. (1)

117. Which of the following is paramagnetic ?
 (1) N_2 (2) H_2 (3) Li_2 (4) O_2
Ans. (4)
118. Which of the following is the correct order of dipole moment ?
 (1) $NH_3 < BF_3 < NF_3 < H_2O$ (2) $BF_3 < NF_3 < NH_3 < H_2O$
 (3) $BF_3 < NH_3 < NF_3 < H_2O$ (4) $H_2O < NF_3 < NH_3 < BF_3$
Ans. (2)
119. Crude sodium chloride obtained by crystallization of brine solution does not contain -
 (1) $MgSO_4$ (2) Na_2SO_4 (3) $MgCl_2$ (4) $CaSO_4$
Ans. (4)
120. Which of the alkali metal chloride (MCl) forms its dehydrate salt ($MCl \cdot 2H_2O$) easily ?
 (1) $LiCl$ (2) $CsCl$ (3) $RbCl$ (4) KCl
Ans. (1)
121. The pH of 0.01 M NaOH (aq) solution will be -
 (1) 7.01 (2) 2 (3) 12 (4) 9
Ans. (3)
122. Which of the following cannot act both as Bronsted acid and as Bronsted base ?
 (1) HCO_3^- (2) NH_3 (3) HCl (4) HSO_4^-
Ans. (3)
123. The molar solubility of CaF_2 ($K_{sp} = 5.3 \times 10^{-11}$) in 0.1 M solution of NaF will be -
 (1) $5.3 \times 10^{-11} \text{ mol L}^{-1}$
 (2) $5.3 \times 10^{-8} \text{ mol L}^{-1}$
 (3) $5.3 \times 10^{-9} \text{ mol L}^{-1}$
 (4) $5.3 \times 10^{-10} \text{ mol L}^{-1}$
Ans. (2)
124. The oxidation state of Cr in CrO_6 is -
 (1) -6
 (2) +12
 (3) +6
 (4) +4
Ans. (3)
125. The number of hydrogen bonded water molecule(s) associated with $CuSO_4 \cdot 5H_2O$ is -
 (1) 3
 (2) 1
 (3) 2
 (4) 5
Ans. (2)
126. Formula of nickel oxide with metal deficiency defect in its crystal is $Ni_{0.98}O$. The crystal contains Ni^{2+} and Ni^{3+} ions. The fraction of nickel existing as Ni^{2+} ions in the crystal is -
 (1) 0.96
 (2) 0.04
 (3) 0.50
 (4) 0.31
Ans. (1)

127. Which of the following statements is correct regarding a solution of two component A and B exhibiting positive deviation from ideal behavior ?
- (1) Intermolecular attractive force between A-A and B-B are stronger than those between A-B.
 - (2) $\Delta_{\text{mix}} H = 0$ at constant T and P.
 - (3) $\Delta_{\text{mix}} V = 0$ at constant T and P.
 - (4) Intermolecular attractive forces between A-A and B-B are equal to those between A-B.

Ans. (1)

128. In water saturated air, the mole fraction of water vapour is 0.02. If the total pressure of the saturated air is 1.2 atm, the partial pressure of dry air is -

- (1) 1.18 atm
- (2) 1.76 atm
- (3) 1.176 atm
- (4) 0.98 atm

Ans. (3)

129. The standard electrode potential (E°) value of Al^{3+}/Al , Ag^+/Ag , K^+/K and Cr^{3+}/Cr are -1.66 V, 0.80 V, -2.93 V & -0.79 V respectively. The correct decreasing order of reducing power of the metal is -

- (1) $\text{Ag} > \text{Cr} > \text{Al} > \text{K}$
- (2) $\text{K} > \text{Al} > \text{Cr} > \text{Ag}$
- (3) $\text{K} > \text{Al} > \text{Ag} > \text{Cr}$
- (4) $\text{Al} > \text{K} > \text{Ag} > \text{Cr}$

Ans. (2)

130. The density of 2 M aqueous solution of NaOH is 1.28 g/cm^3 . The molality of the solution is [Given that molecular mass of NaOH = 40 g mol^{-1}]

- (1) 1.20 m
- (2) 1.56 m
- (3) 1.67 m
- (4) 1.32 m

Ans. (3)

131. Orbital having 3 angular nodes and 3 total nodes is :

- (1) 5 p
- (2) 3 d
- (3) 4 f
- (4) 6 d

Ans. (3)

132. In hydrogen atom, the de Broglie wavelength of an electron in the second Bohr orbit is: [Given that Bohr radius, $a_0 = 52.9 \text{ pm}$]

- (1) 211.6 pm
- (2) $211.6 \pi \text{ pm}$
- (3) $52.9 \pi \text{ pm}$
- (4) 105.8 pm

Ans. (3)

133. The volume occupied by 1.8 g of water vapour at 374°C and 1 bar pressure will be - [Use $R = 0.083 \text{ bar L K}^{-1} \text{ mol}^{-1}$]

- (1) 96.66 L
- (2) 55.87 L
- (3) 3.10 L
- (4) 5.37 L

Ans. (4)

134. An ideal gas expands isothermally from 10^{-3} m^3 to 10^{-2} m^3 at 300 K against a constant pressure of 10^5 Nm^{-2} . The work done on the gas is :

- (1) $+270 \text{ kJ}$
- (2) -900 J
- (3) $+900 \text{ kJ}$
- (4) -900 kJ

Ans. (2)

135. Reversible expansion of an ideal gas under isothermal and adiabatic conditions are as shown in the figure :

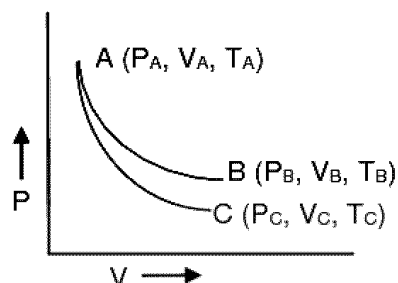

AB \longrightarrow Isothermal expansion

AC \longrightarrow Adiabatic expansion

Which of the following options is not correct?

- (1) $\Delta S_{\text{isothermal}} > \Delta S_{\text{adiabatic}}$
- (2) $T_A = T_B$
- (3) $W_{\text{isothermal}} > W_{\text{adiabatic}}$
- (4) $T_C > T_A$

Ans. (4)

PART - C (PHYSICS)

136. Two metal spheres, one of radius R and the other of radius $2R$ respectively have the same surface charge density σ . They are brought in contact and separated. What will be the new surface charge densities on them?

(1) $\sigma_1 = \frac{5}{6}\sigma, \sigma_2 = \frac{5}{6}\sigma$

(2) $\sigma_1 = \frac{5}{2}\sigma, \sigma_2 = \frac{5}{6}\sigma$

(3) $\sigma_1 = \frac{5}{2}\sigma, \sigma_2 = \frac{5}{3}\sigma$

(4) $\sigma_1 = \frac{5}{3}\sigma, \sigma_2 = \frac{5}{6}\sigma$

Ans. (4)

137. The distance covered by a particle undergoing SHM in one time period is (amplitude = A),

(1) zero

(2) A

(3) $2A$

(4) $4A$

Ans. (4)

138. A mass falls from a height ' h ' and its time of fall ' t ' is recorded in terms of time period T of a simple pendulum. On the surface of earth it is found that $t = 2T$. The entire set up is taken on the surface of another planet whose mass is half of that of earth and radius the same. Same experiment is repeated and corresponding times noted as ' t' ' and ' T' '. Then we can say

(1) $t' = \sqrt{2}T'$

(2) $t' > 2T'$

(3) $t' < 2T'$

(4) $t' = 2T'$

Ans. (4)

139. A tuning fork with frequency 800 Hz produces resonance in a resonance column tube with upper end open and lower end closed by water surface. Successive resonances are observed at lengths 9.75 cm, 31.25 cm and 52.75 cm. The speed of sound in air is,

(1) 500 m/s

(2) 156 m/s

(3) 344 m/s

(4) 172 m/s

Ans. (3)

140. An object flying in air with velocity $(20\hat{i} + 25\hat{j} - 12\hat{k})$ suddenly breaks into two pieces whose masses are in the ratio $1 : 5$. The smaller mass flies off with a velocity $(100\hat{i} + 35\hat{j} + 8\hat{k})$. The velocity of the larger piece will be.

(1) $4\hat{i} + 23\hat{j} - 16\hat{k}$

(2) $-100\hat{i} - 35\hat{j} - 8\hat{k}$

(3) $20\hat{i} + 15\hat{j} - 80\hat{k}$

(4) $-20\hat{i} - 15\hat{j} - 80\hat{k}$

Ans. (1)

141. An object kept in a large room having air temperature of 25°C takes 12 minutes to cool from 80°C to 70°C .

The time taken to cool for the same object from 70° to 60°C would be nearly,

(1) 10 min

(2) 12 min

(3) 20 min

(4) 15 min

Ans. (4)

142. Two small spherical metal balls, having equal masses, are made from materials of densities ρ_1 and ρ_2 ($\rho_1 = 8\rho_2$) and having radii of 1 mm and 2 mm, respectively. They are made to fall vertically (from rest) in a viscous medium whose coefficient of viscosity equals η and whose density is $0.1\rho_2$. The ratio of their terminal velocities would be,

(1) $\frac{79}{72}$

(2) $\frac{19}{36}$

(3) $\frac{39}{72}$

(4) $\frac{79}{36}$

Ans. (4)

143. A particle starting from rest, moves in a circle of radius 'r'. It attains a velocity of V_0 m/s in the n^{th} round. Its angular acceleration will be:

- (1) $\frac{V_0}{n}$ rad/s² (2) $\frac{V_0^2}{2\pi nr^2}$ rad/s² (3) $\frac{V_0^2}{4\pi nr^2}$ rad/s² (4) $\frac{V_0^2}{4\pi nr}$ rad/s²

Ans. (3)

144. A person standing on the floor of an elevator drops a coin. The coin reaches the floor in time t_1 if the elevator is moving uniformly. Then

- (1) $t_1 < t_2$ or $t_1 > t_2$ depending upon whether the lift is going up or down
 (2) $t_1 < t_2$
 (3) $t_1 > t_2$
 (4) $t_1 = t_2$

Ans. (4)

145. A truck is stationary and has a bob suspended by a light string, in a frame attached to the truck. The truck, suddenly moves to the right with an acceleration of a . The pendulum will tilt

- (1) to the left and angle of inclination of the pendulum with the vertical is $\sin^{-1}\left(\frac{g}{a}\right)$
 (2) to the left and angle of inclination of the pendulum with the vertical is $\tan^{-1}\left(\frac{a}{g}\right)$
 (3) to the left and angle of inclination of the pendulum with the vertical is $\sin^{-1}\left(\frac{a}{g}\right)$
 (4) to the left and angle of inclination of the pendulum with the vertical is $\tan^{-1}\left(\frac{g}{a}\right)$

Ans. (2)

146. In a u-tube as shown in the figure water and oil are in the left side and right side of the tube respectively. The heights from the bottom for water and oil columns are 15 cm and 20 cm respectively. The density of the oil is: <http://www.xamstudy.com>
 [take $\rho_{\text{water}} = 1000 \text{ kg/m}^3$]

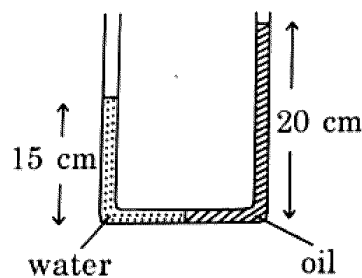

- (1) 1200 kg/m^3 (2) 750 kg/m^3 (3) 1000 kg/m^3 (4) 1333 kg/m^3

Ans. (2)

147. A deep rectangular pond of surface area A , containing water (density = ρ , specific heat capacity = s), is located in a region where the outside air temperature is at a steady value of -26°C . The thickness of the frozen ice layer in this pond, at a certain instant is x .

Taking the thermal conductivity of ice as K , and its specific latent heat of fusion as L , the rate of increase of the thickness of ice layer, at this instant, would be given by

- (1) $26K/\rho x(L-4s)$ (2) $26K/(\rho x^2 L)$ (3) $26K/(\rho x L)$ (4) $26K/\rho x(L+4s)$

Ans. (3)

148. An LED is constructed from a p-n junction diode using GaAsP. The energy gap is 1.9 eV. The wavelength of the light emitted will be equal to
 (1) 10.4×10^{-26} m (2) 654 nm (3) 654 Å (4) 654×10^{-11} m

Ans. (2)

149. The circuit diagram shown here corresponds to the logic gate,

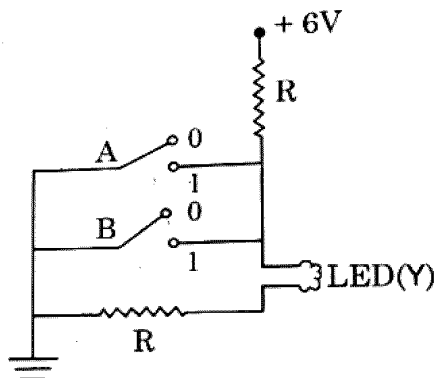

- Ans. (1) NOR (2) AND (3) OR (4) NAND

150. The value of $\gamma \left(= \frac{C_p}{C_v} \right)$, for hydrogen helium and another ideal diatomic gas X (whose molecules are not rigid but have an additional vibrational mode), are respectively equal to,

- (1) $\frac{7}{5}, \frac{5}{3}, \frac{9}{7}$ (2) $\frac{5}{3}, \frac{7}{5}, \frac{9}{7}$ (3) $\frac{5}{3}, \frac{7}{5}, \frac{7}{5}$ (4) $\frac{7}{5}, \frac{5}{3}, \frac{7}{5}$

Ans. (1)

151. An equiconvex lens has power P. It is cut into two symmetrical halves by a plane containing the principal axis. The power of one part will be,

- (1) 0 (2) $\frac{P}{2}$ (3) $\frac{P}{4}$ (4) P

Ans. (4)

152. In Young's double slit experiment, if there is no initial phase difference between the light from the two slits, a point on the screen corresponding to the fifth minimum has path difference

- (1) $5 \frac{\lambda}{2}$ (2) $10 \frac{\lambda}{2}$ (3) $9 \frac{\lambda}{2}$ (4) $11 \frac{\lambda}{2}$

Ans. (3)

153. A double convex lens has focal length 25 cm. The radius of curvature of one of the surfaces is double of the other. Find the radii if the refractive index of the material of the lens is 1.5.

- (1) 100 cm, 50 cm (2) 25 cm, 50 cm (3) 18.75 cm, 37.5 cm (4) 50 cm, 100 cm

Ans. (3)

154. Two bullets are fired horizontally and simultaneously towards each other from roof tops of two buildings 100 m apart and of same height of 200 m, with the same velocity of 25 m/s. When and where will the two bullets collide? ($g = 10 \text{ m/s}^2$)

- (1) after 2s at a height of 180 m (2) after 2s at a height of 20 m
 (3) after 4s at a height of 120 m (4) they will not collide

Ans. (1)

155. The stress-strain curves are drawn for two different materials X and Y. It is observed that the ultimate strength point and the fracture point are close to each other for material X but are far apart for material Y. We can say the materials X and Y are likely to be (respectively),
 (1) ductile and brittle (2) brittle and ductile (3) brittle and plastic (4) plastic and ductile

Ans. (2)

156. A body of mass m is kept on a rough horizontal surface (coefficient of friction = μ). A horizontal force is applied on the body, but it does not move. The resultant of normal reaction and the frictional force acting on the object is given by F , where F is,

(1) $|\vec{F}| = mg + \mu mg$ (2) $|\vec{F}| = \mu mg$ (3) $|\vec{F}| \leq mg\sqrt{1 + \mu^2}$ (4) $|\vec{F}| = mg$

Ans. (3)

157. A particle of mass $5m$ at rest suddenly breaks on its own into three fragments. Two fragments of mass m each move along mutually perpendicular direction with speed v each. The energy released during the process is,

(1) $\frac{3}{5}mv^2$ (2) $\frac{5}{3}mv^2$ (3) $\frac{3}{2}mv^2$ (4) $\frac{4}{3}mv^2$

Ans. (4)

158. An object of mass 500 g, initially at rest, is acted upon by a variable force whose X-component varies with X in the manner shown. The velocities of the object at the points $X = 8\text{ m}$ and $X = 12\text{ m}$, would have the respective values of (nearly)

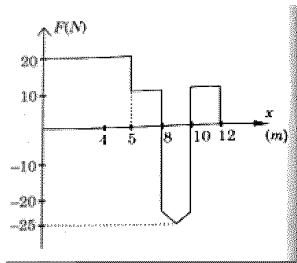

- (1) 18 m/s and 24.4 m/s (2) 23 m/s and 24.4 m/s
 (3) 23 m/s and 20.6 m/s (4) 18 m/s and 20.6 m/s

Ans. (3)

159. A solid cylinder of mass 2 kg and radius 50 cm rolls up an inclined plane of angle of inclination 30° . The centre of mass of the cylinder has speed of 4 m/s. The distance travelled by the cylinder on the inclined surface will be, [take $g = 10\text{ m/s}^2$]

- (1) 2.2 m (2) 1.6 m (3) 1.2 m (4) 2.4 m

Ans. (4)

160. Two toroids 1 and 2 have total no. of turns 200 and 100 respectively with average radii 40 cm and 20 cm respectively. If they carry same current i , the ratio of the magnetic fields along the two loops is
 (1) 1 : 1 (2) 4 : 1 (3) 2 : 1 (4) 1 : 2

Ans. (1)

161. A straight conductor carrying current I splits into two parts as shown in the figure. The radius of the circular loop is R . The total magnetic field at the centre P of the loop is,

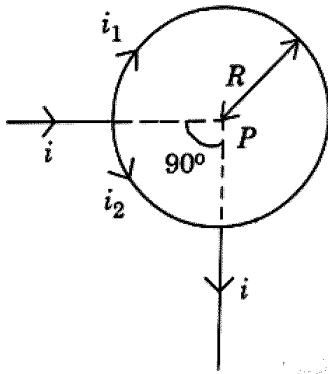

- (1) zero (2) $3\mu_0 i / 32R$, outward (3) $3\mu_0 i / 32R$, inward (4) $\frac{\mu_0 i}{2R}$, inward

Ans. (1)

162. The variation of EMF with time for four types of generators are shown in the figures. Which amongst them can be called AC ?

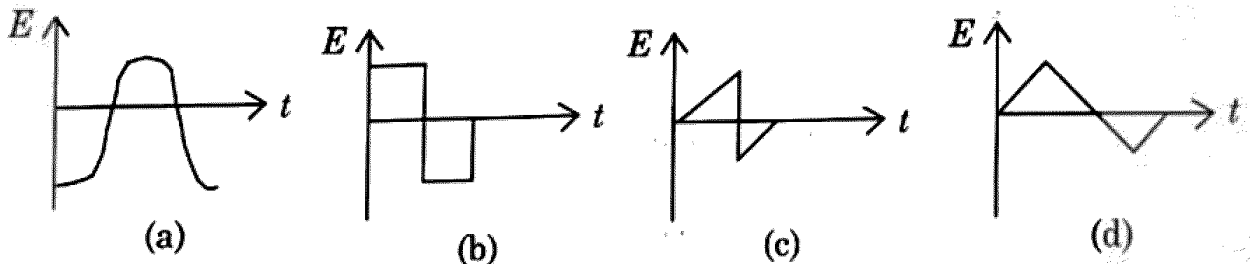

- (1) (a) and (d) (2) (a), (b), (c), (d) (3) (a) and (b) (4) only (a)

Ans. (2)

163. The radius of the first permitted Bohr orbit, for the electron, in a hydrogen atom equals 0.51\AA and its ground state energy equals -13.6 eV . If the electron in the hydrogen atom is replaced by muon (μ^-) [charge same as electron and mass $207 m_e$], the first Bohr radius and ground state energy will be

- (1) $0.53 \times 10^{-13}\text{ m}$, -3.6 eV (2) $25.6 \times 10^{-13}\text{ m}$, -2.8 eV
 (3) $2.56 \times 10^{-13}\text{ m}$, -2.8 keV (4) $2.56 \times 10^{-13}\text{ m}$, -13.6 eV

Ans. (3)

164. The reading of an ideal voltmeter in the circuit shown is

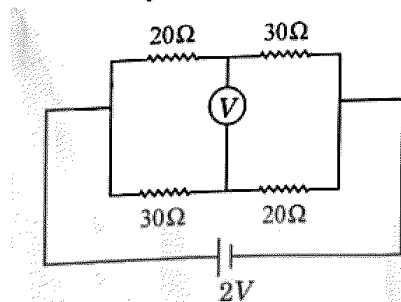

- (1) 0.6 V (2) 0 V (3) 0.5 V (4) 0.4 V

Ans. (4)

165. The metre bridge shown is in balance position with $\frac{P}{Q} = \frac{\ell_1}{\ell_2}$. If we now interchange the positions of galvanometer and cell, will the bridge work? If yes, what will be balance condition?

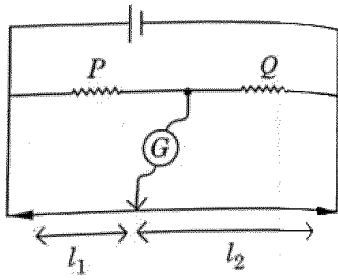

- (1) yes, $\frac{P}{Q} = \frac{\ell_1 - \ell_1}{\ell_2 + \ell_1}$ (2) no, no null point (3) yes, $\frac{P}{Q} = \frac{\ell_2}{\ell_1}$ (4) yes, $\frac{P}{Q} = \frac{\ell_1}{\ell_2}$

Ans. (4)

166. The relations amongst the three elements of earth's magnetic field, namely horizontal component H , vertical component V and dip δ are, (B_E = total magnetic field)

- (1) $V = B_E \tan \delta$, $H = B_E$ (2) $V = B_E \sin \delta$, $H = B_E \cos \delta$
 (3) $V = B_E \cos \delta$, $H = B_E \sin \delta$ (4) $V = B_E$, $H = B_E \tan \delta$

Ans. (2)

167. The rate of radioactive disintegration at an instant for a radioactive sample of half life 2.2×10^9 s is 10^{10} s^{-1} . The number of radioactive atoms in that sample at that instant is :

- (1) 3.17×10^{20} (2) 3.17×10^{17} (3) 3.17×10^{18} (4) 3.17×10^{19}

Ans (4)

168. The time period of a geostationary satellite is 24 h, at a height $6R_E$ (R_E is radius of earth) from surface of earth. The time period of another satellite whose height is $2.5 R_E$ from surface will be :

- (1) $6\sqrt{2}h$ (2) $12\sqrt{2}h$ (3) $\frac{24}{2.5}h$ (4) $\frac{12}{2.5}h$

Ans (1)

169. A circuit when connected to an AC source of 12 V gives a current of 0.2A. The same circuit when connected to a DC source of 12 V, gives a current of 0.4 A. The circuit is :

- (1) series LR (2) series RC (3) series LC (4) series LCR

Ans (1)

170. A cycle wheel of radius 0.5 m is rotated with constant angular velocity of 10 rad/s in a region of magnetic field of 0.1 T which is perpendicular to the plane of the wheel. The EMF generated between its centre and the rim is :

- (1) 0.25 V (2) 0.125 V (3) 0.5 V (4) zero

Ans (2)

171. For a transparent medium, relative permeability and permittivity, μ_r and ϵ_r are 1.0 and 1.44 respectively. The velocity of light in this medium would be :

- (1) 2.5×10^8 (2) 3×10^8 (3) $2.08 \times 10^8 \text{ m/s}$ (4) $4.32 \times 10^8 \text{ m/s}$

Ans (1)

172. A sphere encloses an electric dipole with charges $\pm 3 \times 10^{-6} \text{ C}$. What is the total electric flux across the sphere?

- (1) -3×10^{-6} (2) Zero (3) $3 \times 10^{-6} \text{ Nm}^2/\text{C}$ (4) $6 \times 10^{-6} \text{ Nm}^2/\text{C}$

Ans (2)

173. Two identical capacitors C_1 and C_2 of equal capacitance are connected as shown in the circuit. Terminals a and b of the key k are connected to charge capacitor C_1 using battery of emf V volt. Now disconnecting a and b the terminals b and c are connected. Due to this, what will be the percentage loss of energy?

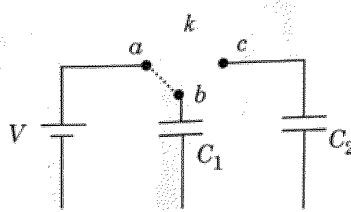

- (1) 75% (2) 0% (3) 50% (4) 25%

Ans. (3)

174. The main scale of a vernier calipers has n divisions/cm. n division of the vernier scale coincide with $(n - 1)$ divisions of main scale. The least count of the vernier calipers is :

- (1) $\frac{1}{(n+1)(n-1)}$ cm (2) $\frac{1}{n}$ cm (3) $\frac{1}{n^2}$ cm (4) $\frac{1}{n(n+1)}$ cm

Ans (3)

175. A person traveling in a straight line moves with a constant velocity v_1 for certain distance 'x' and with a constant velocity v_2 for next equal distance. The average velocity v is given by the relation :

- (1) $\frac{1}{v} = \frac{1}{v_1} + \frac{1}{v_2}$ (2) $\frac{2}{v} = \frac{1}{v_1} + \frac{1}{v_2}$ (3) $\frac{v}{2} = \frac{v_1 + v_2}{2}$ (4) $v = \sqrt{v_1 v_2}$

Ans (2)

176. Assuming that the gravitational potential energy of an object at infinity is zero, the change in potential energy (final – initial) of an object of mass m , when taken to a height h from the surface of earth (of radius R), is given by :

- (1) $-\frac{GMm}{R+h}$ (2) $\frac{GMmh}{R(R+h)}$ (3) mgh (4) $\frac{GMm}{R+h}$

Ans (2)

177. 1 g of water, of volume 1 cm^3 at 100°C , is converted into steam at same temperature under normal atmospheric pressure $\approx 1 \times 10^5 \text{ Pa}$. The volume of steam formed equals 1671 cm^3 . If the specific latent heat of vaporization of water is 2256 J/g , the change in internal energy is :

- (1) 2423 J (2) 2089 J (3) 167 J (4) 2256 J

Ans (2)

178. Angular width of the central maximum in the Fraunhofer diffraction for $\lambda = 6000 \text{ \AA}$ is θ_0 . When the same slit is illuminated by another monochromatic light, the angular width decreases by 30%. The wavelength of this light is :

- (1) 1800 \AA (2) 4200 \AA (3) 6000 \AA (4) 420 \AA

Ans (2)

179. The work function of a photosensitive material is 4.0 eV . The longest wavelength of light that can cause photon emission from the substance is (approximately)

- (1) 3100 nm (2) 966 nm (3) 31 nm (4) 310 nm

Ans (4)

180. A proton and an α -particle are accelerated from rest to the same energy. The de Broglie wavelength λ_p and λ_α are in the ratio :

- (1) $2 : 1$ (2) $1 : 1$ (3) $\sqrt{2} : 1$ (4) $4 : 1$

Ans (1)