

Q6

This Booklet contains 24 pages.

Do not open this Test Booklet until you are asked to do so.

Important Instructions :

1. The Answer Sheet is inside this Test Booklet. When you are directed to open the Test Booklet, take out the Answer Sheet and fill in the particulars on **side-1** and **side-2** carefully with **blue/black** ball point pen only.
2. The test is of **3 hours** duration and Test Booklet contains **180** questions. Each question carries **4** marks. For each correct response, the candidate will get **4** marks. For each incorrect response, **one mark** will be deducted from the total scores. The maximum marks are **720**.
3. Use **Blue/Black Ball Point Pen only** for writing particulars on this page/markings responses.
4. Rough work is to be done on the space provided for this purpose in the Test Booklet only.
5. **On completion of the test, the candidate must hand over the Answer Sheet to the invigilator before leaving the Room/Hall. The candidates are allowed to take away this Test Booklet with them.**
6. The CODE for this Booklet is **Q6**. Make sure that the CODE printed on **Side-2** of the Answer Sheet is the same as that on this Test Booklet. In case of discrepancy, the candidate should immediately report the matter to the Invigilator for replacement of both the Test Booklet and the Answer Sheet.
7. The candidates should ensure that the Answer Sheet is not folded. Do not make any stray marks on the Answer Sheet. Do not write your Roll No. anywhere else except in the specified space in the Test Booklet/ Answer Sheet.
8. Use of white fluid for correction is **NOT** permissible on the Answer Sheet.
9. Each candidate must show on demand his/her Admit Card to the Invigilator.
10. No candidate, without special permission of the Superintendent or Invigilator, would leave his/her seat.
11. The candidates should not leave the Examination Hall without handing over their Answer Sheet to the Invigilator on duty and sign the Attendance Sheet twice. **Cases where a candidate has not signed the Attendance Sheet second time will be deemed not to have handed over the Answer Sheet and dealt with as an unfair means case.**
12. Use of Electronic/Manual Calculator is prohibited.
13. The candidates are governed by all Rules and Regulations of the examination with regard to their conduct in the Examination Hall. All cases of unfair means will be dealt with as per Rules and Regulations of this examination.
14. No part of the Test Booklet and Answer Sheet shall be detached under any circumstances.
15. The candidates will write the Correct Test Booklet Code as given in the Test Booklet/Answer Sheet in the Attendance Sheet.

Name of the Candidate (in Capitals) : _____

Roll Number : in figures _____

: in words _____

Centre of Examination (in Capitals) : _____

Candidate's Signature : _____ Invigilator's Signature : _____

Fascimile signature stamp of

Centre Superintendent : _____

Q6

2

1. The biodegradable polymer is :

- (1) nylon 2-nylon 6
- (2) nylon-6
- (3) Buna-S
- (4) nylon-6, 6

2. For the second period elements the correct increasing order of first ionisation enthalpy is :

- (1) $\text{Li} < \text{B} < \text{Be} < \text{C} < \text{O} < \text{N} < \text{F} < \text{Ne}$
- (2) $\text{Li} < \text{B} < \text{Be} < \text{C} < \text{N} < \text{O} < \text{F} < \text{Ne}$
- (3) $\text{Li} < \text{Be} < \text{B} < \text{C} < \text{O} < \text{N} < \text{F} < \text{Ne}$
- (4) $\text{Li} < \text{Be} < \text{B} < \text{C} < \text{N} < \text{O} < \text{F} < \text{Ne}$

3. The major product of the following reaction is :

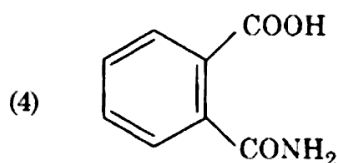
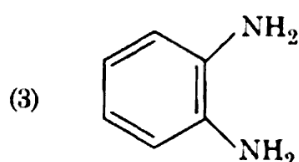
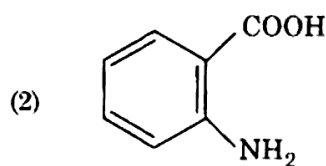
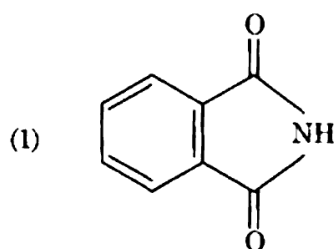
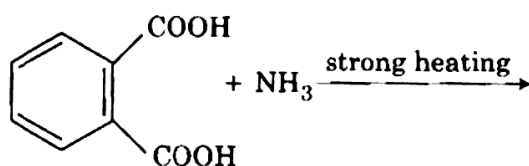

4. Under isothermal condition, a gas at 300 K expands from 0.1 L to 0.25 L against a constant external pressure of 2 bar. The work done by the gas is :

[Given that 1 L bar = 100 J]

- (1) 5 kJ
- (2) 25 J
- (3) 30 J
- (4) - 30 J

5. The number of sigma (σ) and pi (π) bonds in pent-2-en-4-yne is :

- (1) 8 σ bonds and 5 π bonds
- (2) 11 σ bonds and 2 π bonds
- (3) 13 σ bonds and no π bond
- (4) 10 σ bonds and 3 π bonds

6. Which is the correct thermal stability order for H_2E (E = O, S, Se, Te and Po) ?

- (1) $\text{H}_2\text{O} < \text{H}_2\text{S} < \text{H}_2\text{Se} < \text{H}_2\text{Te} < \text{H}_2\text{Po}$
- (2) $\text{H}_2\text{Po} < \text{H}_2\text{Te} < \text{H}_2\text{Se} < \text{H}_2\text{S} < \text{H}_2\text{O}$
- (3) $\text{H}_2\text{Se} < \text{H}_2\text{Te} < \text{H}_2\text{Po} < \text{H}_2\text{O} < \text{H}_2\text{S}$
- (4) $\text{H}_2\text{S} < \text{H}_2\text{O} < \text{H}_2\text{Se} < \text{H}_2\text{Te} < \text{H}_2\text{Po}$

7. The manganate and permanganate ions are tetrahedral, due to :

- (1) There is no π -bonding
- (2) The π -bonding involves overlap of p-orbitals of oxygen with p-orbitals of manganese
- (3) The π -bonding involves overlap of d-orbitals of oxygen with d-orbitals of manganese
- (4) The π -bonding involves overlap of p-orbitals of oxygen with d-orbitals of manganese

8. The method used to remove temporary hardness of water is :

- (1) Clark's method
- (2) Ion-exchange method
- (3) Synthetic resins method
- (4) Calgon's method

9. Which one is malachite from the following ?

- (1) $\text{Cu}(\text{OH})_2$
- (2) Fe_3O_4
- (3) $\text{CuCO}_3 \cdot \text{Cu}(\text{OH})_2$
- (4) CuFeS_2

10. A gas at 350 K and 15 bar has molar volume 20 percent smaller than that for an ideal gas under the same conditions. The correct option about the gas and its compressibility factor (Z) is :

- (1) $Z > 1$ and repulsive forces are dominant
- (2) $Z < 1$ and attractive forces are dominant
- (3) $Z < 1$ and repulsive forces are dominant
- (4) $Z > 1$ and attractive forces are dominant

11. Among the following, the one that is **not** a green house gas is :

- (1) methane
- (2) ozone
- (3) sulphur dioxide
- (4) nitrous oxide

12. Identify the **incorrect** statement related to PCl_5 from the following :

- (1) Two axial P–Cl bonds make an angle of 180° with each other
- (2) Axial P–Cl bonds are longer than equatorial P–Cl bonds
- (3) PCl_5 molecule is non-reactive
- (4) Three equatorial P–Cl bonds make an angle of 120° with each other

13. Among the following, the reaction that proceeds through an electrophilic substitution, is :

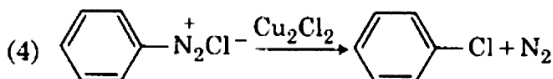
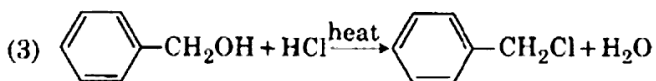
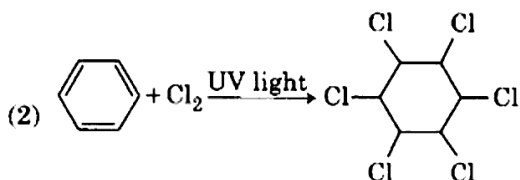
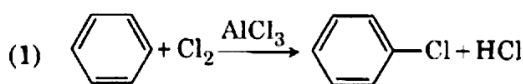

14. Match the following :

- | | |
|----------------------|-----------------------------------|
| (a) Pure nitrogen | (i) Chlorine |
| (b) Haber process | (ii) Sulphuric acid |
| (c) Contact process | (iii) Ammonia |
| (d) Deacon's process | (iv) Sodium azide or Barium azide |

Which of the following is the correct option ?

- | | (a) | (b) | (c) | (d) |
|-----|-------|-------|-------|-------|
| (1) | (ii) | (iv) | (i) | (iii) |
| (2) | (iii) | (iv) | (ii) | (i) |
| (3) | (iv) | (iii) | (ii) | (i) |
| (4) | (i) | (ii) | (iii) | (iv) |

15. What is the correct electronic configuration of the central atom in $\text{K}_4[\text{Fe}(\text{CN})_6]$ based on crystal field theory ?

- (1) $t_{2g}^6 e_g^0$
- (2) $e^3 t_2^3$
- (3) $e^4 t_2^2$
- (4) $t_{2g}^4 e_g^2$

16. Which of the following reactions are disproportionation reaction ?

- (a) $2\text{Cu}^+ \rightarrow \text{Cu}^{2+} + \text{Cu}^0$
- (b) $3\text{MnO}_4^{2-} + 4\text{H}^+ \rightarrow 2\text{MnO}_4^- + \text{MnO}_2 + 2\text{H}_2\text{O}$
- (c) $2\text{KMnO}_4 \xrightarrow{\Delta} \text{K}_2\text{MnO}_4 + \text{MnO}_2 + \text{O}_2$
- (d) $2\text{MnO}_4^- + 3\text{Mn}^{2+} + 2\text{H}_2\text{O} \rightarrow 5\text{MnO}_2 + 4\text{H}^+$

Select the correct option from the following :

- (1) (a), (b) and (c)
- (2) (a), (c) and (d)
- (3) (a) and (d) only
- (4) (a) and (b) only

17. For the cell reaction

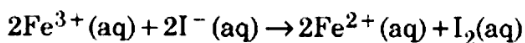

$E_{\text{cell}}^\ominus = 0.24 \text{ V}$ at 298 K. The standard Gibbs energy ($\Delta_r G^\ominus$) of the cell reaction is :

[Given that Faraday constant $F = 96500 \text{ C mol}^{-1}$]

- (1) $-23.16 \text{ kJ mol}^{-1}$
- (2) $46.32 \text{ kJ mol}^{-1}$
- (3) $23.16 \text{ kJ mol}^{-1}$
- (4) $-46.32 \text{ kJ mol}^{-1}$

18. Enzymes that utilize ATP in phosphate transfer require an alkaline earth metal (M) as the cofactor. M is :

- (1) Mg
- (2) Ca
- (3) Sr
- (4) Be

19. The correct structure of tribromooctaoxide is :

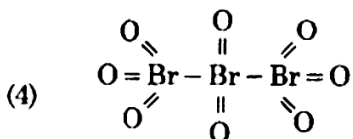
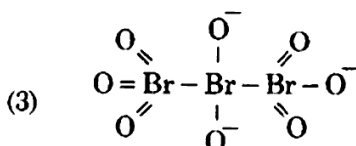
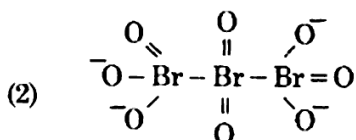
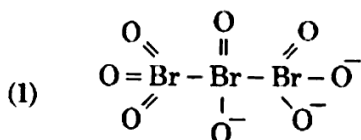

20. Conjugate base for Brønsted acids H_2O and HF are :

- (1) H_3O^+ and F^- , respectively
- (2) OH^- and F^- , respectively
- (3) H_3O^+ and H_2F^+ , respectively
- (4) OH^- and H_2F^+ , respectively

21. The compound that is most difficult to protonate is :

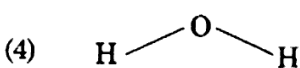
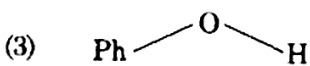
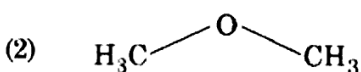
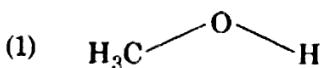

22. For a cell involving one electron $E_{\text{cell}}^\ominus = 0.59 \text{ V}$ at 298 K, the equilibrium constant for the cell reaction is :

$$\left[\text{Given that } \frac{2.303 RT}{F} = 0.059 \text{ V at } T = 298 \text{ K} \right]$$

- (1) 1.0×10^5
- (2) 1.0×10^{10}
- (3) 1.0×10^{30}
- (4) 1.0×10^2

23. Which of the following species is not stable ?

- (1) $[\text{GeCl}_6]^{2-}$
- (2) $[\text{Sn}(\text{OH})_6]^{2-}$
- (3) $[\text{SiCl}_6]^{2-}$
- (4) $[\text{SiF}_6]^{2-}$

24. For the chemical reaction

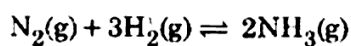

the correct option is :

- (1) $-\frac{d[\text{N}_2]}{dt} = 2 \frac{d[\text{NH}_3]}{dt}$
- (2) $-\frac{d[\text{N}_2]}{dt} = \frac{1}{2} \frac{d[\text{NH}_3]}{dt}$
- (3) $3 \frac{d[\text{H}_2]}{dt} = 2 \frac{d[\text{NH}_3]}{dt}$
- (4) $-\frac{1}{3} \frac{d[\text{H}_2]}{dt} = -\frac{1}{2} \frac{d[\text{NH}_3]}{dt}$

25. Which will make basic buffer ?

- (1) 100 mL of 0.1 M CH_3COOH + 100 mL of 0.1 M NaOH
- (2) 100 mL of 0.1 M HCl + 200 mL of 0.1 M NH_4OH
- (3) 100 mL of 0.1 M HCl + 100 mL of 0.1 M NaOH
- (4) 50 mL of 0.1 M NaOH + 25 mL of 0.1 M CH_3COOH

26. The most suitable reagent for the following conversion, is :

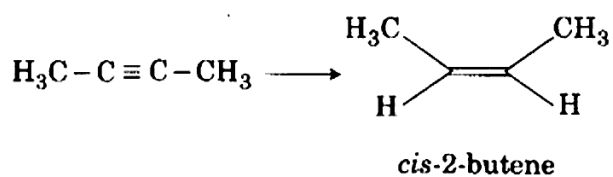

- (1) H_2 , Pd/C, quinoline
 (2) Zn/HCl
 (3) $\text{Hg}^{2+}/\text{H}^+$, H_2O
 (4) Na/liquid NH_3
27. Which of the following diatomic molecular species has only π bonds according to Molecular Orbital Theory ?
- (1) N_2
 (2) C_2
 (3) Be_2
 (4) O_2
28. An alkene "A" on reaction with O_3 and Zn- H_2O gives propanone and ethanal in equimolar ratio. Addition of HCl to alkene "A" gives "B" as the major product. The structure of product "B" is :

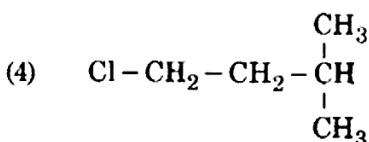
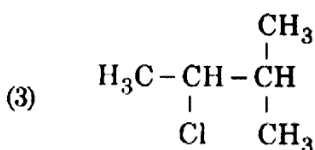
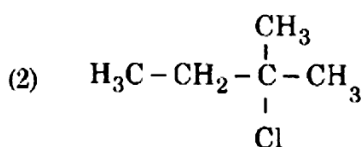
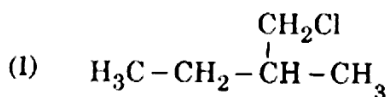

29. For an ideal solution, the correct option is :

- (1) $\Delta_{\text{mix}} V \neq 0$ at constant T and P
 (2) $\Delta_{\text{mix}} H = 0$ at constant T and P
 (3) $\Delta_{\text{mix}} G = 0$ at constant T and P
 (4) $\Delta_{\text{mix}} S = 0$ at constant T and P

30. The correct order of the basic strength of methyl substituted amines in aqueous solution is :

- (1) $(\text{CH}_3)_3\text{N} > \text{CH}_3\text{NH}_2 > (\text{CH}_3)_2\text{NH}$
 (2) $(\text{CH}_3)_3\text{N} > (\text{CH}_3)_2\text{NH} > \text{CH}_3\text{NH}_2$
 (3) $\text{CH}_3\text{NH}_2 > (\text{CH}_3)_2\text{NH} > (\text{CH}_3)_3\text{N}$
 (4) $(\text{CH}_3)_2\text{NH} > \text{CH}_3\text{NH}_2 > (\text{CH}_3)_3\text{N}$

31. The structure of intermediate A in the following reaction, is :

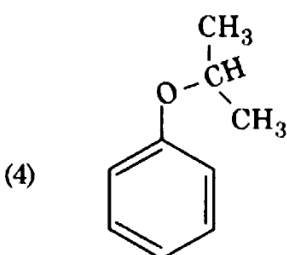
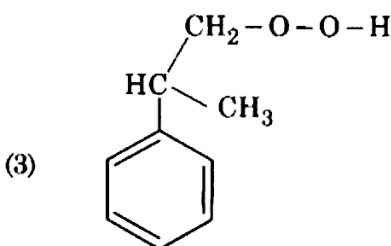
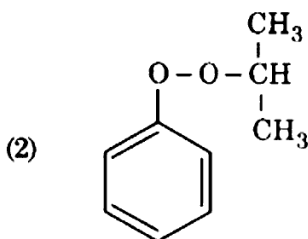
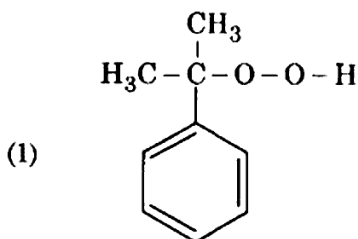
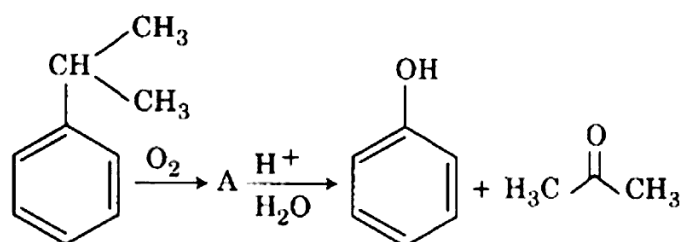

32. If the rate constant for a first order reaction is k , the time (t) required for the completion of 99% of the reaction is given by :
- (1) $t = 6.909/k$
 - (2) $t = 4.606/k$
 - (3) $t = 2.303/k$
 - (4) $t = 0.693/k$
33. Which mixture of the solutions will lead to the formation of negatively charged colloidal $[AgI]I^-$ sol. ?
- (1) 50 mL of 1 M $AgNO_3$ + 50 mL of 2 M KI
 - (2) 50 mL of 2 M $AgNO_3$ + 50 mL of 1.5 M KI
 - (3) 50 mL of 0.1 M $AgNO_3$ + 50 mL of 0.1 M KI
 - (4) 50 mL of 1 M $AgNO_3$ + 50 mL of 1.5 M KI
34. Match the Xenon compounds in **Column - I** with its structure in **Column - II** and assign the correct code :
- | Column - I | Column - II |
|--------------|----------------------------|
| (a) XeF_4 | (i) pyramidal |
| (b) XeF_6 | (ii) square planar |
| (c) $XeOF_4$ | (iii) distorted octahedral |
| (d) XeO_3 | (iv) square pyramidal |
- Code :
- | | (a) | (b) | (c) | (d) |
|-----|-------|-------|-------|------|
| (1) | (ii) | (iii) | (iv) | (i) |
| (2) | (ii) | (iii) | (i) | (iv) |
| (3) | (iii) | (iv) | (i) | (ii) |
| (4) | (i) | (ii) | (iii) | (iv) |
35. Which of the following is incorrect statement ?
- (1) $SiCl_4$ is easily hydrolysed
 - (2) GeX_4 ($X = F, Cl, Br, I$) is more stable than GeX_2
 - (3) SnF_4 is ionic in nature
 - (4) PbF_4 is covalent in nature
36. 4d, 5p, 5f and 6p orbitals are arranged in the order of decreasing energy. The correct option is :
- (1) $6p > 5f > 5p > 4d$
 - (2) $6p > 5f > 4d > 5p$
 - (3) $5f > 6p > 4d > 5p$
 - (4) $5f > 6p > 5p > 4d$
37. Which of the following series of transitions in the spectrum of hydrogen atom falls in visible region ?
- (1) Balmer series
 - (2) Paschen series
 - (3) Brackett series
 - (4) Lyman series
38. The non-essential amino acid among the following is :
- (1) leucine
 - (2) alanine
 - (3) lysine
 - (4) valine
39. Which of the following is an amphoteric hydroxide ?
- (1) $Ca(OH)_2$
 - (2) $Mg(OH)_2$
 - (3) $Be(OH)_2$
 - (4) $Sr(OH)_2$
40. Among the following, the narrow spectrum antibiotic is :
- (1) ampicillin
 - (2) amoxycillin
 - (3) chloramphenicol
 - (4) penicillin G
41. In which case change in entropy is negative ?
- (1) Expansion of a gas at constant temperature
 - (2) Sublimation of solid to gas
 - (3) $2H(g) \rightarrow H_2(g)$
 - (4) Evaporation of water
42. A compound is formed by cation C and anion A. The anions form hexagonal close packed (hcp) lattice and the cations occupy 75% of octahedral voids. The formula of the compound is :
- (1) C_3A_2
 - (2) C_3A_4
 - (3) C_4A_3
 - (4) C_2A_3

43. The number of moles of hydrogen molecules required to produce 20 moles of ammonia through Haber's process is :

- (1) 20
- (2) 30
- (3) 40
- (4) 10

44. pH of a saturated solution of $\text{Ca}(\text{OH})_2$ is 9. The solubility product (K_{sp}) of $\text{Ca}(\text{OH})_2$ is :

- (1) 0.25×10^{-10}
- (2) 0.125×10^{-15}
- (3) 0.5×10^{-10}
- (4) 0.5×10^{-15}

45. The mixture that forms maximum boiling azeotrope is :

- (1) Ethanol + Water
- (2) Acetone + Carbon disulphide
- (3) Heptane + Octane
- (4) Water + Nitric acid

46. The radius of circle, the period of revolution, initial position and sense of revolution are indicated in the fig.

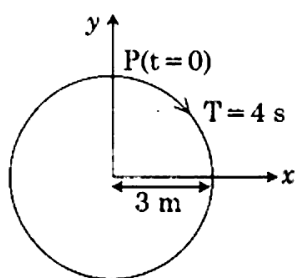

y - projection of the radius vector of rotating particle P is :

- (1) $y(t) = 4 \sin\left(\frac{\pi t}{2}\right)$, where y in m
- (2) $y(t) = 3 \cos\left(\frac{3\pi t}{2}\right)$, where y in m
- (3) $y(t) = 3 \cos\left(\frac{\pi t}{2}\right)$, where y in m
- (4) $y(t) = -3 \cos 2\pi t$, where y in m

47. A hollow metal sphere of radius R is uniformly charged. The electric field due to the sphere at a distance r from the centre :

- (1) zero as r increases for $r < R$, decreases as r increases for $r > R$
- (2) zero as r increases for $r < R$, increases as r increases for $r > R$
- (3) decreases as r increases for $r < R$ and for $r > R$
- (4) increases as r increases for $r < R$ and for $r > R$

48. When a block of mass M is suspended by a long wire of length L , the length of the wire becomes $(L + l)$. The elastic potential energy stored in the extended wire is :

- (1) MgL
- (2) $\frac{1}{2} Mgl$
- (3) $\frac{1}{2} MgL$
- (4) Mgl

49. In total internal reflection when the angle of incidence is equal to the critical angle for the pair of media in contact, what will be angle of refraction? <http://www.xamstudy.com>

- (1) 0°
- (2) equal to angle of incidence
- (3) 90°
- (4) 180°

50.

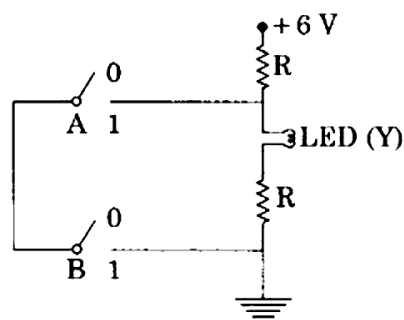

The correct Boolean operation represented by the circuit diagram drawn is :

- (1) OR
- (2) NAND
- (3) NOR
- (4) AND

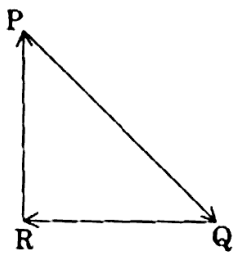
51. Which of the following acts as a circuit protection device ?
- (1) inductor
 - (2) switch
 - (3) fuse
 - (4) conductor
52. In which of the following devices, the eddy current effect is **not** used ?
- (1) magnetic braking in train
 - (2) electromagnet
 - (3) electric heater
 - (4) induction furnace
53. Two similar thin equi-convex lenses, of focal length f each, are kept coaxially in contact with each other such that the focal length of the combination is F_1 . When the space between the two lenses is filled with glycerin (which has the same refractive index ($\mu = 1.5$) as that of glass) then the equivalent focal length is F_2 . The ratio $F_1 : F_2$ will be :
- (1) 1 : 2
 - (2) 2 : 3
 - (3) 3 : 4
 - (4) 2 : 1
54. The unit of thermal conductivity is :
- (1) $\text{J m}^{-1} \text{K}^{-1}$
 - (2) W m K^{-1}
 - (3) $\text{W m}^{-1} \text{K}^{-1}$
 - (4) J m K^{-1}
55. Pick the **wrong** answer in the context with rainbow.
- (1) The order of colours is reversed in the secondary rainbow.
 - (2) An observer can see a rainbow when his front is towards the sun.
 - (3) Rainbow is a combined effect of dispersion, refraction and reflection of sunlight.
 - (4) When the light rays undergo two internal reflections in a water drop, a secondary rainbow is formed.
56. Body A of mass $4m$ moving with speed u collides with another body B of mass $2m$, at rest. The collision is head on and elastic in nature. After the collision the fraction of energy lost by the colliding body A is :
- (1) $\frac{8}{9}$
 - (2) $\frac{4}{9}$
 - (3) $\frac{5}{9}$
 - (4) $\frac{1}{9}$
57. Ionized hydrogen atoms and α -particles with same momenta enters perpendicular to a constant magnetic field, B. The ratio of their radii of their paths $r_H : r_\alpha$ will be :
- (1) 1 : 2
 - (2) 4 : 1
 - (3) 1 : 4
 - (4) 2 : 1
58. A particle moving with velocity \vec{v} is acted by three forces shown by the vector triangle PQR. The velocity of the particle will :
- 
- (1) decrease
 - (2) remain constant
 - (3) change according to the smallest force \vec{QR}
 - (4) increase
59. For a p-type semiconductor, which of the following statements is **true** ?
- (1) Holes are the majority carriers and trivalent atoms are the dopants.
 - (2) Holes are the majority carriers and pentavalent atoms are the dopants.
 - (3) Electrons are the majority carriers and pentavalent atoms are the dopants.
 - (4) Electrons are the majority carriers and trivalent atoms are the dopants.

60. A cylindrical conductor of radius R is carrying a constant current. The plot of the magnitude of the magnetic field, B with the distance, d , from the centre of the conductor, is correctly represented by the figure :

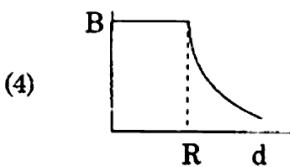
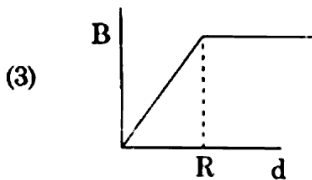
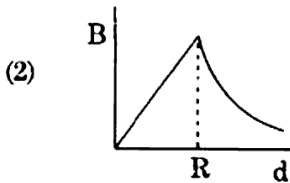
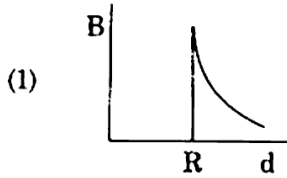

61. A disc of radius 2 m and mass 100 kg rolls on a horizontal floor. Its centre of mass has speed of 20 cm/s. How much work is needed to stop it ?

- (1) 30 kJ
 (2) 2 J
 (3) 1 J
 (4) 3 J

62. A block of mass 10 kg is in contact against the inner wall of a hollow cylindrical drum of radius 1 m. The coefficient of friction between the block and the inner wall of the cylinder is 0.1. The minimum angular velocity needed for the cylinder to keep the block stationary when the cylinder is vertical and rotating about its axis, will be : ($g = 10 \text{ m/s}^2$)

- (1) $\frac{10}{2\pi} \text{ rad/s}$
 (2) 10 rad/s
 (3) $10\pi \text{ rad/s}$
 (4) $\sqrt{10} \text{ rad/s}$

63. In an experiment, the percentage of error occurred in the measurement of physical quantities A, B, C and D are 1%, 2%, 3% and 4% respectively. Then the maximum percentage of error in the

measurement X, where $X = \frac{A^2 B^{1/2}}{C^{1/3} D^3}$, will be :

- (1) 16%
 (2) -10%
 (3) 10%
 (4) $\left(\frac{3}{13}\right)\%$

64. A copper rod of 88 cm and an aluminium rod of unknown length have their increase in length independent of increase in temperature. The length of aluminium rod is : ($\alpha_{\text{Cu}} = 1.7 \times 10^{-5} \text{ K}^{-1}$ and $\alpha_{\text{Al}} = 2.2 \times 10^{-5} \text{ K}^{-1}$)

- (1) 113.9 cm
 (2) 88 cm
 (3) 68 cm
 (4) 6.8 cm

65. A force $F = 20 + 10y$ acts on a particle in y -direction where F is in newton and y in meter. Work done by this force to move the particle from $y = 0$ to $y = 1$ m is :

- (1) 5 J
 (2) 25 J
 (3) 20 J
 (4) 30 J

66. An electron is accelerated through a potential difference of 10,000 V. Its de Broglie wavelength is, (nearly) : ($m_e = 9 \times 10^{-31} \text{ kg}$)

- (1) $12.2 \times 10^{-12} \text{ m}$
 (2) $12.2 \times 10^{-14} \text{ m}$
 (3) 12.2 nm
 (4) $12.2 \times 10^{-13} \text{ m}$

67. The work done to raise a mass m from the surface of the earth to a height h , which is equal to the radius of the earth, is :

- (1) $2 mgR$
- (2) $\frac{1}{2} mgR$
- (3) $\frac{3}{2} mgR$
- (4) mgR

68. At a point A on the earth's surface the angle of dip, $\delta = +25^\circ$. At a point B on the earth's surface the angle of dip, $\delta = -25^\circ$. We can interpret that :

- (1) A is located in the southern hemisphere and B is located in the northern hemisphere.
- (2) A is located in the northern hemisphere and B is located in the southern hemisphere.
- (3) A and B are both located in the southern hemisphere.
- (4) A and B are both located in the northern hemisphere.

69. A soap bubble, having radius of 1 mm, is blown from a detergent solution having a surface tension of $2.5 \times 10^{-2} \text{ N/m}$. The pressure inside the bubble equals at a point Z_0 below the free surface of water in a container. Taking $g = 10 \text{ m/s}^2$, density of water = 10^3 kg/m^3 , the value of Z_0 is :

- (1) 10 cm
- (2) 1 cm
- (3) 0.5 cm
- (4) 100 cm

70. In the circuits shown below, the readings of the voltmeters and the ammeters will be :

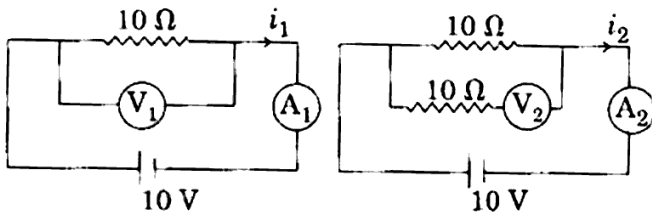

Circuit 1

Circuit 2

- (1) $V_1 = V_2$ and $i_1 > i_2$
- (2) $V_1 = V_2$ and $i_1 = i_2$
- (3) $V_2 > V_1$ and $i_1 > i_2$
- (4) $V_2 > V_1$ and $i_1 = i_2$

71. Six similar bulbs are connected as shown in the figure with a DC source of emf E , and zero internal resistance.

The ratio of power consumption by the bulbs when (i) all are glowing and (ii) in the situation when two from section A and one from section B are glowing, will be :

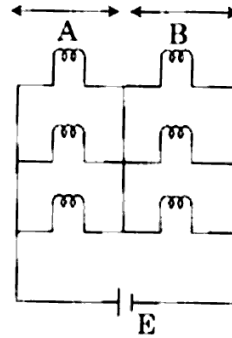

- (1) 9 : 4
- (2) 1 : 2
- (3) 2 : 1
- (4) 4 : 9

72. A mass m is attached to a thin wire and whirled in a vertical circle. The wire is most likely to break when :

- (1) the wire is horizontal
- (2) the mass is at the lowest point
- (3) inclined at an angle of 60° from vertical
- (4) the mass is at the highest point

73. In which of the following processes, heat is neither absorbed nor released by a system ?

- (1) adiabatic
- (2) isobaric
- (3) isochoric
- (4) isothermal

74. Two point charges A and B, having charges $+Q$ and $-Q$ respectively, are placed at certain distance apart and force acting between them is F . If 25% charge of A is transferred to B, then force between the charges becomes :

- (1) $\frac{9F}{16}$
- (2) $\frac{16F}{9}$
- (3) $\frac{4F}{3}$
- (4) F

75. When an object is shot from the bottom of a long smooth inclined plane kept at an angle 60° with horizontal, it can travel a distance x_1 along the plane. But when the inclination is decreased to 30° and the same object is shot with the same velocity, it can travel x_2 distance. Then $x_1 : x_2$ will be :
- (1) $\sqrt{2} : 1$
 - (2) $1 : \sqrt{3}$
 - (3) $1 : 2\sqrt{3}$
 - (4) $1 : \sqrt{2}$
76. A solid cylinder of mass 2 kg and radius 4 cm is rotating about its axis at the rate of 3 rpm. The torque required to stop after 2π revolutions is :
- (1) $2 \times 10^{-3} \text{ N m}$
 - (2) $12 \times 10^{-4} \text{ N m}$
 - (3) $2 \times 10^6 \text{ N m}$
 - (4) $2 \times 10^{-6} \text{ N m}$
77. Increase in temperature of a gas filled in a container would lead to :
- (1) increase in its kinetic energy
 - (2) decrease in its pressure
 - (3) decrease in intermolecular distance
 - (4) increase in its mass
78. In a double slit experiment, when light of wavelength 400 nm was used, the angular width of the first minima formed on a screen placed 1 m away, was found to be 0.2° . What will be the angular width of the first minima, if the entire experimental apparatus is immersed in water? ($\mu_{\text{water}} = 4/3$)
- (1) 0.15°
 - (2) 0.05°
 - (3) 0.1°
 - (4) 0.266°
79. A parallel plate capacitor of capacitance $20 \mu\text{F}$ is being charged by a voltage source whose potential is changing at the rate of 3 V/s. The conduction current through the connecting wires, and the displacement current through the plates of the capacitor, would be, respectively :
- (1) $60 \mu\text{A}, 60 \mu\text{A}$
 - (2) $60 \mu\text{A}, \text{zero}$
 - (3) zero, zero
 - (4) $\text{zero}, 60 \mu\text{A}$
80. The speed of a swimmer in still water is 20 m/s. The speed of river water is 10 m/s and is flowing due east. If he is standing on the south bank and wishes to cross the river along the shortest path, the angle at which he should make his strokes w.r.t. north is given by :
- (1) 0°
 - (2) 60° west
 - (3) 45° west
 - (4) 30° west
81. Average velocity of a particle executing SHM in one complete vibration is :
- (1) $A\omega$
 - (2) $\frac{A\omega^2}{2}$
 - (3) zero
 - (4) $\frac{A\omega}{2}$
82. The displacement of a particle executing simple harmonic motion is given by
 $y = A_0 + A \sin \omega t + B \cos \omega t$.
 Then the amplitude of its oscillation is given by :
- (1) $\sqrt{A^2 + B^2}$
 - (2) $\sqrt{A_0^2 + (A + B)^2}$
 - (3) $A + B$
 - (4) $A_0 + \sqrt{A^2 + B^2}$

83. A small hole of area of cross-section 2 mm^2 is present near the bottom of a fully filled open tank of height 2 m. Taking $g = 10 \text{ m/s}^2$, the rate of flow of water through the open hole would be nearly :
- (1) $8.9 \times 10^{-6} \text{ m}^3/\text{s}$
 - (2) $2.23 \times 10^{-6} \text{ m}^3/\text{s}$
 - (3) $6.4 \times 10^{-6} \text{ m}^3/\text{s}$
 - (4) $12.6 \times 10^{-6} \text{ m}^3/\text{s}$
84. Two parallel infinite line charges with linear charge densities $+\lambda \text{ C/m}$ and $-\lambda \text{ C/m}$ are placed at a distance of $2R$ in free space. What is the electric field mid-way between the two line charges ?
- (1) $\frac{2\lambda}{\pi\epsilon_0 R} \text{ N/C}$
 - (2) $\frac{\lambda}{\pi\epsilon_0 R} \text{ N/C}$
 - (3) $\frac{\lambda}{2\pi\epsilon_0 R} \text{ N/C}$
 - (4) zero
85. Two particles A and B are moving in uniform circular motion in concentric circles of radii r_A and r_B with speed v_A and v_B respectively. Their time period of rotation is the same. The ratio of angular speed of A to that of B will be :
- (1) $v_A : v_B$
 - (2) $r_B : r_A$
 - (3) $1 : 1$
 - (4) $r_A : r_B$
86. A 800 turn coil of effective area 0.05 m^2 is kept perpendicular to a magnetic field $5 \times 10^{-5} \text{ T}$. When the plane of the coil is rotated by 90° around any of its coplanar axis in 0.1 s, the emf induced in the coil will be :
- (1) 0.2 V
 - (2) $2 \times 10^{-3} \text{ V}$
 - (3) 0.02 V
 - (4) 2 V
87. Which colour of the light has the longest wavelength ?
- (1) blue
 - (2) green
 - (3) violet
 - (4) red
88. The total energy of an electron in an atom in an orbit is -3.4 eV . Its kinetic and potential energies are, respectively :
- (1) $-3.4 \text{ eV}, -6.8 \text{ eV}$
 - (2) $3.4 \text{ eV}, -6.8 \text{ eV}$
 - (3) $3.4 \text{ eV}, 3.4 \text{ eV}$
 - (4) $-3.4 \text{ eV}, -3.4 \text{ eV}$
89. α -particle consists of :
- (1) 2 electrons, 2 protons and 2 neutrons
 - (2) 2 electrons and 4 protons only
 - (3) 2 protons only
 - (4) 2 protons and 2 neutrons only
90. A body weighs 200 N on the surface of the earth. How much will it weigh half way down to the centre of the earth ?
- (1) 200 N
 - (2) 250 N
 - (3) 100 N
 - (4) 150 N
91. Match the Column - I with Column - II :
- | Column - I | Column - II |
|---------------------------------------|-----------------------------------|
| (a) P - wave | (i) Depolarisation of ventricles |
| (b) QRS complex | (ii) Repolarisation of ventricles |
| (c) T - wave | (iii) Coronary ischemia |
| (d) Reduction in the size of T - wave | (iv) Depolarisation of atria |
| | (v) Repolarisation of atria |
- Select the correct option.
- | | (a) | (b) | (c) | (d) |
|-----|------|-------|------|-------|
| (1) | (iv) | (i) | (ii) | (v) |
| (2) | (ii) | (i) | (v) | (iii) |
| (3) | (ii) | (iii) | (v) | (iv) |
| (4) | (iv) | (i) | (ii) | (iii) |

92. Expressed Sequence Tags (ESTs) refers to :

- (1) Polypeptide expression
- (2) DNA polymorphism
- (3) Novel DNA sequences
- (4) Genes expressed as RNA

93. Which one of the following is **not** a method of *in situ* conservation of biodiversity ?

- (1) Wildlife Sanctuary
- (2) Botanical Garden
- (3) Sacred Grove
- (4) Biosphere Reserve

94. The Earth Summit held in Rio de Janeiro in 1992 was called :

- (1) for conservation of biodiversity and sustainable utilization of its benefits.
- (2) to assess threat posed to native species by invasive weed species.
- (3) for immediate steps to discontinue use of CFCs that were damaging the ozone layer.
- (4) to reduce CO₂ emissions and global warming.

95. From evolutionary point of view, retention of the female gametophyte with developing young embryo on the parent sporophyte for some time, is first observed in :

- (1) Mosses
- (2) Pteridophytes
- (3) Gymnosperms
- (4) Liverworts

96. DNA precipitation out of a mixture of biomolecules can be achieved by treatment with :

- (1) Chilled ethanol
- (2) Methanol at room temperature
- (3) Chilled chloroform
- (4) Isopropanol

97. Match the following organisms with their respective characteristics :

- | | |
|--------------------------|-------------------------|
| (a) <i>Pila</i> | (i) Flame cells |
| (b) <i>Bombyx</i> | (ii) Comb plates |
| (c) <i>Pleurobrachia</i> | (iii) Radula |
| (d) <i>Taenia</i> | (iv) Malpighian tubules |

Select the **correct** option from the following :

- | | (a) | (b) | (c) | (d) |
|-----|-------|------|-------|------|
| (1) | (iii) | (iv) | (ii) | (i) |
| (2) | (ii) | (iv) | (iii) | (i) |
| (3) | (iii) | (ii) | (iv) | (i) |
| (4) | (iii) | (ii) | (i) | (iv) |

98. Which of the following statements is **not** correct ?

- (1) The hydrolytic enzymes of lysosomes are active under acidic pH.
- (2) Lysosomes are membrane bound structures.
- (3) Lysosomes are formed by the process of packaging in the endoplasmic reticulum.
- (4) Lysosomes have numerous hydrolytic enzymes.

99. The concept of "*Omnis cellula-e cellula*" regarding cell division was first proposed by :

- (1) Theodore Schwann
- (2) Schleiden
- (3) Aristotle
- (4) Rudolf Virchow

100. *Thiobacillus* is a group of bacteria helpful in carrying out :

- (1) Chemoautotrophic fixation
- (2) Nitrification
- (3) Denitrification
- (4) Nitrogen fixation

101. How does steroid hormone influence the cellular activities ?

- (1) Binding to DNA and forming a gene-hormone complex.
- (2) Activating cyclic AMP located on the cell membrane.
- (3) Using aquaporin channels as second messenger.
- (4) Changing the permeability of the cell membrane.

102. Which of the following pairs of gases is mainly responsible for green house effect ?
- (1) Oxygen and Nitrogen
 - (2) Nitrogen and Sulphur dioxide
 - (3) Carbon dioxide and Methane
 - (4) Ozone and Ammonia
103. Which of the following is a commercial blood cholesterol lowering agent ?
- (1) Statin
 - (2) Streptokinase
 - (3) Lipases
 - (4) Cyclosporin A
104. Consider following features :
- (a) Organ system level of organisation
 - (b) Bilateral symmetry
 - (c) True coelomates with segmentation of body
- Select the **correct** option of animal groups which possess all the above characteristics.
- (1) Annelida, Arthropoda and Mollusca
 - (2) Arthropoda, Mollusca and Chordata
 - (3) Annelida, Mollusca and Chordata
 - (4) Annelida, Arthropoda and Chordata
105. Colostrum, the yellowish fluid, secreted by mother during the initial days of lactation is very essential to impart immunity to the newborn infants because it contains :
- (1) Monocytes
 - (2) Macrophages
 - (3) Immunoglobulin A
 - (4) Natural killer cells
106. A gene locus has two alleles A, a. If the frequency of dominant allele A is 0.4, then what will be the frequency of homozygous dominant, heterozygous and homozygous recessive individuals in the population ?
- (1) 0.16 (AA); 0.24 (Aa); 0.36 (aa)
 - (2) 0.16 (AA); 0.48 (Aa); 0.36 (aa)
 - (3) 0.16 (AA); 0.36 (Aa); 0.48 (aa)
 - (4) 0.36 (AA); 0.48 (Aa); 0.16 (aa)
107. Identify the **correct** pair representing the causative agent of typhoid fever and the confirmatory test for typhoid.
- (1) *Streptococcus pneumoniae* / Widal test
 - (2) *Salmonella typhi* / Anthrone test
 - (3) *Salmonella typhi* / Widal test
 - (4) *Plasmodium vivax* / UTI test
108. The frequency of recombination between gene pairs on the same chromosome as a measure of the distance between genes was explained by :
- (1) Gregor J. Mendel
 - (2) Alfred Sturtevant
 - (3) Sutton Boveri
 - (4) T.H. Morgan
109. It takes very long time for pineapple plants to produce flowers. Which combination of hormones can be applied to artificially induce flowering in pineapple plants throughout the year to increase yield ?
- (1) Gibberellin and Cytokinin
 - (2) Gibberellin and Abscisic acid
 - (3) Cytokinin and Abscisic acid
 - (4) Auxin and Ethylene
110. Respiratory Quotient (RQ) value of tripalmitin is :
- (1) 0.7
 - (2) 0.07
 - (3) 0.09
 - (4) 0.9
111. Match the hominids with their **correct** brain size :
- | | | | |
|----------------------------------|--|--------------------|--|
| (a) <i>Homo habilis</i> | | (i) 900 cc | |
| (b) <i>Homo neanderthalensis</i> | | (ii) 1350 cc | |
| (c) <i>Homo erectus</i> | | (iii) 650 - 800 cc | |
| (d) <i>Homo sapiens</i> | | (iv) 1400 cc | |
- Select the **correct** option.
- | | (a) | (b) | (c) | (d) |
|-----|-------|-------|------|------|
| (1) | (iii) | (ii) | (i) | (iv) |
| (2) | (iii) | (iv) | (i) | (ii) |
| (3) | (iv) | (iii) | (i) | (ii) |
| (4) | (iii) | (i) | (iv) | (ii) |

112. Which of the following ecological pyramids is generally inverted ?
- (1) Pyramid of energy
 - (2) Pyramid of biomass in a forest
 - (3) Pyramid of biomass in a sea
 - (4) Pyramid of numbers in grassland
113. Which of these following methods is the most suitable for disposal of nuclear waste ?
- (1) Bury the waste under Antarctic ice-cover
 - (2) Dump the waste within rocks under deep ocean
 - (3) Bury the waste within rocks deep below the Earth's surface
 - (4) Shoot the waste into space
114. The correct sequence of phases of cell cycle is :
- (1) $G_1 \rightarrow G_2 \rightarrow S \rightarrow M$
 - (2) $S \rightarrow G_1 \rightarrow G_2 \rightarrow M$
 - (3) $G_1 \rightarrow S \rightarrow G_2 \rightarrow M$
 - (4) $M \rightarrow G_1 \rightarrow G_2 \rightarrow S$
115. Variations caused by mutation, as proposed by Hugo de Vries, are :
- (1) random and directionless
 - (2) small and directional
 - (3) small and directionless
 - (4) random and directional
116. Match the following genes of the Lac operon with their respective products :
- | | |
|------------|----------------------------|
| (a) i gene | (i) β -galactosidase |
| (b) z gene | (ii) Permease |
| (c) a gene | (iii) Repressor |
| (d) y gene | (iv) Transacetylase |
- Select the correct option.
- | | (a) | (b) | (c) | (d) |
|-----|-------|-------|------|------|
| (1) | (iii) | (i) | (ii) | (iv) |
| (2) | (iii) | (i) | (iv) | (ii) |
| (3) | (iii) | (iv) | (i) | (ii) |
| (4) | (i) | (iii) | (ii) | (iv) |
117. In *Antirrhinum* (Snapdragon), a red flower was crossed with a white flower and in F_1 generation, pink flowers were obtained. When pink flowers were selfed, the F_2 generation showed white, red and pink flowers. Choose the incorrect statement from the following :
- (1) Pink colour in F_1 is due to incomplete dominance.
 - (2) Ratio of F_2 is $\frac{1}{4}$ (Red) : $\frac{2}{4}$ (Pink) : $\frac{1}{4}$ (White)
 - (3) Law of Segregation does not apply in this experiment.
 - (4) This experiment does not follow the Principle of Dominance. <http://www.xamstudy.com>
118. The shorter and longer arms of a submetacentric chromosome are referred to as :
- (1) p-arm and q-arm respectively
 - (2) q-arm and p-arm respectively
 - (3) m-arm and n-arm respectively
 - (4) s-arm and l-arm respectively
119. Which of the following factors is responsible for the formation of concentrated urine ?
- (1) Maintaining hyperosmolarity towards inner medullary interstitium in the kidneys.
 - (2) Secretion of erythropoietin by Juxtaglomerular complex.
 - (3) Hydrostatic pressure during glomerular filtration.
 - (4) Low levels of antidiuretic hormone.
120. Match the following hormones with the respective disease :
- | | |
|--------------------|-------------------------|
| (a) Insulin | (i) Addison's disease |
| (b) Thyroxin | (ii) Diabetes insipidus |
| (c) Corticoids | (iii) Acromegaly |
| (d) Growth Hormone | (iv) Goitre |
| | (v) Diabetes mellitus |
- Select the correct option.
- | | (a) | (b) | (c) | (d) |
|-----|------|------|-------|-------|
| (1) | (ii) | (iv) | (iii) | (i) |
| (2) | (v) | (iv) | (i) | (iii) |
| (3) | (ii) | (iv) | (i) | (iii) |
| (4) | (v) | (i) | (ii) | (iii) |

121. Grass leaves curl inwards during very dry weather. Select the most appropriate reason from the following :
- (1) Flaccidity of bulliform cells
 - (2) Shrinkage of air spaces in spongy mesophyll
 - (3) Tyloses in vessels
 - (4) Closure of stomata
122. What would be the heart rate of a person if the cardiac output is 5 L, blood volume in the ventricles at the end of diastole is 100 mL and at the end of ventricular systole is 50 mL ?
- (1) 75 beats per minute
 - (2) 100 beats per minute
 - (3) 125 beats per minute
 - (4) 50 beats per minute
123. Which of the following immune responses is responsible for rejection of kidney graft ?
- (1) Humoral immune response
 - (2) Inflammatory immune response
 - (3) Cell-mediated immune response
 - (4) Auto-immune response
124. Which of the following features of genetic code does allow bacteria to produce human insulin by recombinant DNA technology ?
- (1) Genetic code is redundant
 - (2) Genetic code is nearly universal
 - (3) Genetic code is specific
 - (4) Genetic code is not ambiguous
125. Select the **incorrect** statement.
- (1) Inbreeding is essential to evolve purelines in any animal.
 - (2) Inbreeding selects harmful recessive genes that reduce fertility and productivity.
 - (3) Inbreeding helps in accumulation of superior genes and elimination of undesirable genes.
 - (4) Inbreeding increases homozygosity.
126. What is the direction of movement of sugars in phloem ?
- (1) Upward
 - (2) Downward
 - (3) Bi-directional
 - (4) Non-multidirectional
127. What is the genetic disorder in which an individual has an overall masculine development, gynaecomastia, and is sterile ?
- (1) Klinefelter's syndrome
 - (2) Edward syndrome
 - (3) Down's syndrome
 - (4) Turner's syndrome
128. What is the site of perception of photoperiod necessary for induction of flowering in plants ?
- (1) Pulvinus
 - (2) Shoot apex
 - (3) Leaves
 - (4) Lateral buds
129. Following statements describe the characteristics of the enzyme Restriction Endonuclease. Identify the **incorrect** statement.
- (1) The enzyme binds DNA at specific sites and cuts only one of the two strands.
 - (2) The enzyme cuts the sugar-phosphate backbone at specific sites on each strand.
 - (3) The enzyme recognizes a specific palindromic nucleotide sequence in the DNA.
 - (4) The enzyme cuts DNA molecule at identified position within the DNA.
130. Polyblend, a fine powder of recycled modified plastic, has proved to be a good material for :
- (1) use as a fertilizer
 - (2) construction of roads
 - (3) making tubes and pipes
 - (4) making plastic sacks

131. Cells in G_0 phase :
- (1) enter the cell cycle
 - (2) suspend the cell cycle
 - (3) terminate the cell cycle
 - (4) exit the cell cycle
132. Which of the following protocols did aim for reducing emission of chlorofluorocarbons into the atmosphere ?
- (1) Kyoto Protocol
 - (2) Gothenburg Protocol
 - (3) Geneva Protocol
 - (4) Montreal Protocol
133. Due to increasing air-borne allergens and pollutants, many people in urban areas are suffering from respiratory disorder causing wheezing due to :
- (1) inflammation of bronchi and bronchioles.
 - (2) proliferation of fibrous tissues and damage of the alveolar walls.
 - (3) reduction in the secretion of surfactants by pneumocytes.
 - (4) benign growth on mucous lining of nasal cavity.
134. Which of the following statements is **incorrect** ?
- (1) Viruses are obligate parasites.
 - (2) Infective constituent in viruses is the protein coat.
 - (3) Prions consist of abnormally folded proteins.
 - (4) Viroids lack a protein coat.
135. Purines found both in DNA and RNA are :
- (1) Adenine and guanine
 - (2) Guanine and cytosine
 - (3) Cytosine and thymine
 - (4) Adenine and thymine
136. Which of the statements given below is **not** true about formation of Annual Rings in trees ?
- (1) Differential activity of cambium causes light and dark bands of tissue - early and late wood respectively.
 - (2) Activity of cambium depends upon variation in climate.
 - (3) Annual rings are not prominent in trees of temperate region.
 - (4) Annual ring is a combination of spring wood and autumn wood produced in a year.
137. Select the **correct** sequence of organs in the alimentary canal of cockroach starting from mouth :
- (1) Pharynx → Oesophagus → Gizzard → Crop → Ileum → Colon → Rectum
 - (2) Pharynx → Oesophagus → Gizzard → Ileum → Crop → Colon → Rectum
 - (3) Pharynx → Oesophagus → Ileum → Crop → Gizzard → Colon → Rectum
 - (4) Pharynx → Oesophagus → Crop → Gizzard → Ileum → Colon → Rectum
138. What is the fate of the male gametes discharged in the synergid ?
- (1) All fuse with the egg.
 - (2) One fuses with the egg, other(s) fuse(s) with synergid nucleus.
 - (3) One fuses with the egg and other fuses with central cell nuclei.
 - (4) One fuses with the egg, other(s) degenerate(s) in the synergid.
139. Which of the following is **true** for Golden rice ?
- (1) It is pest resistant, with a gene from *Bacillus thuringiensis*.
 - (2) It is drought tolerant, developed using *Agrobacterium* vector.
 - (3) It has yellow grains, because of a gene introduced from a primitive variety of rice.
 - (4) It is Vitamin A enriched, with a gene from daffodil.

140. Select the correct sequence for transport of sperm cells in male reproductive system.

- (1) Seminiferous tubules → Rete testis → Vasa efferentia → Epididymis → Vas deferens → Ejaculatory duct → Urethra → Urethral meatus
- (2) Seminiferous tubules → Vasa efferentia → Epididymis → Inguinal canal → Urethra
- (3) Testis → Epididymis → Vasa efferentia → Vas deferens → Ejaculatory duct → Inguinal canal → Urethra → Urethral meatus
- (4) Testis → Epididymis → Vasa efferentia → Rete testis → Inguinal canal → Urethra

141. Under which of the following conditions will there be no change in the reading frame of following mRNA ?

5' AACAGCGGUGCUAAU 3'

- (1) Deletion of G from 5th position
- (2) Insertion of A and G at 4th and 5th positions respectively
- (3) Deletion of GGU from 7th, 8th and 9th positions
- (4) Insertion of G at 5th position

142. What triggers activation of protoxin to active Bt toxin of *Bacillus thuringiensis* in boll worm ?

- (1) Moist surface of midgut
- (2) Alkaline pH of gut
- (3) Acidic pH of stomach
- (4) Body temperature

143. Consider the following statements :

- (A) Coenzyme or metal ion that is tightly bound to enzyme protein is called prosthetic group.
- (B) A complete catalytic active enzyme with its bound prosthetic group is called apoenzyme.

Select the correct option.

- (1) (A) is true but (B) is false.
- (2) Both (A) and (B) are false.
- (3) (A) is false but (B) is true.
- (4) Both (A) and (B) are true.

144. Select the correctly written scientific name of Mango which was first described by Carolus Linnaeus :

- (1) *Mangifera indica* Linn.
- (2) *Mangifera indica*
- (3) *Mangifera Indica*
- (4) *Mangifera indica* Car. Linn.

145. Pinus seed cannot germinate and establish without fungal association. This is because :

- (1) it has obligate association with mycorrhizae.
- (2) it has very hard seed coat.
- (3) its seeds contain inhibitors that prevent germination.
- (4) its embryo is immature.

146. Match the following structures with their respective location in organs :

- | | | |
|--------------------------|-------|-----------------|
| (a) Crypts of Lieberkühn | (i) | Pancreas |
| (b) Glisson's Capsule | (ii) | Duodenum |
| (c) Islets of Langerhans | (iii) | Small intestine |
| (d) Brunner's Glands | (iv) | Liver |

Select the correct option from the following :

- | | (a) | (b) | (c) | (d) |
|-----|-------|------|------|-------|
| (1) | (ii) | (iv) | (i) | (iii) |
| (2) | (iii) | (iv) | (i) | (ii) |
| (3) | (iii) | (ii) | (i) | (iv) |
| (4) | (iii) | (i) | (ii) | (iv) |

147. Which of the following contraceptive methods do involve a role of hormone ?

- (1) Barrier method, Lactational amenorrhea, Pills
- (2) CuT, Pills, Emergency contraceptives
- (3) Pills, Emergency contraceptives, Barrier methods
- (4) Lactational amenorrhea, Pills, Emergency contraceptives

148. Persistent nucellus in the seed is known as :

- (1) Perisperm
- (2) Hilum
- (3) Tegmen
- (4) Chalaza

149. Select the **incorrect** statement.
- (1) In male grasshoppers, 50% of sperms have no sex-chromosome.
 - (2) In domesticated fowls, sex of progeny depends on the type of sperm rather than egg.
 - (3) Human males have one of their sex-chromosome much shorter than the other.
 - (4) Male fruit fly is heterogametic.
150. Which of the following glucose transporters is insulin-dependent ?
- (1) GLUT II
 - (2) GLUT III
 - (3) GLUT IV
 - (4) GLUT I
151. Select the **correct** option.
- (1) 11th and 12th pairs of ribs are connected to the sternum with the help of hyaline cartilage.
 - (2) Each rib is a flat thin bone and all the ribs are connected dorsally to the thoracic vertebrae and ventrally to the sternum.
 - (3) There are seven pairs of vertebrosteral, three pairs of vertebrochondral and two pairs of vertebral ribs.
 - (4) 8th, 9th and 10th pairs of ribs articulate directly with the sternum.
152. Tidal Volume and Expiratory Reserve Volume of an athlete is 500 mL and 1000 mL respectively. What will be his Expiratory Capacity if the Residual Volume is 1200 mL ?
- (1) 1700 mL
 - (2) 2200 mL
 - (3) 2700 mL
 - (4) 1500 mL
153. Use of an artificial kidney during hemodialysis may result in :
- (a) Nitrogenous waste build-up in the body
 - (b) Non-elimination of excess potassium ions
 - (c) Reduced absorption of calcium ions from gastro-intestinal tract
 - (d) Reduced RBC production
- Which of the following options is the most **appropriate** ?
- (1) (b) and (c) are correct
 - (2) (c) and (d) are correct
 - (3) (a) and (d) are correct
 - (4) (a) and (b) are correct
154. Select the hormone-releasing Intra-Uterine Devices.
- (1) Multiload 375, Progestasert
 - (2) Progestasert, LNG-20
 - (3) Lippes Loop, Multiload 375
 - (4) Vaults, LNG-20
155. Extrusion of second polar body from egg nucleus occurs :
- (1) after fertilization
 - (2) before entry of sperm into ovum
 - (3) simultaneously with first cleavage
 - (4) after entry of sperm but before fertilization
156. Placentation, in which ovules develop on the inner wall of the ovary or in peripheral part, is :
- (1) Axile
 - (2) Parietal
 - (3) Free central
 - (4) Basal
157. Which of the following statements is **incorrect** ?
- (1) *Claviceps* is a source of many alkaloids and LSD.
 - (2) Conidia are produced exogenously and ascospores endogenously.
 - (3) Yeasts have filamentous bodies with long thread-like hyphae.
 - (4) Morels and truffles are edible delicacies.
158. Which of the following sexually transmitted diseases is **not** completely curable ?
- (1) Genital warts
 - (2) Genital herpes
 - (3) Chlamydisias
 - (4) Gonorrhoea
159. Conversion of glucose to glucose-6-phosphate, the first irreversible reaction of glycolysis, is catalyzed by :
- (1) Hexokinase
 - (2) Enolase
 - (3) Phosphofructokinase
 - (4) Aldolase

160. Select the **correct** group of biocontrol agents.

- (1) *Trichoderma*, *Baculovirus*,
Bacillus thuringiensis
- (2) *Oscillatoria*, *Rhizobium*, *Trichoderma*
- (3) *Nostoc*, *Azospirillum*,
Nucleopolyhedrovirus
- (4) *Bacillus thuringiensis*, Tobacco mosaic
virus, Aphids

161. Match the following organisms with the products they produce :

- | | |
|-------------------------------------|-------------------|
| (a) <i>Lactobacillus</i> | (i) Cheese |
| (b) <i>Saccharomyces cerevisiae</i> | (ii) Curd |
| (c) <i>Aspergillus niger</i> | (iii) Citric Acid |
| (d) <i>Acetobacter aceti</i> | (iv) Bread |
| | (v) Acetic Acid |

Select the **correct** option.

- | | (a) | (b) | (c) | (d) |
|-----|-------|------|-------|-------|
| (1) | (ii) | (iv) | (iii) | (v) |
| (2) | (iii) | (iv) | (v) | (i) |
| (3) | (ii) | (i) | (iii) | (v) |
| (4) | (ii) | (iv) | (v) | (iii) |

162. Which of the following statements regarding mitochondria is **incorrect** ?

- (1) Enzymes of electron transport are embedded in outer membrane.
- (2) Inner membrane is convoluted with infoldings.
- (3) Mitochondrial matrix contains single circular DNA molecule and ribosomes.
- (4) Outer membrane is permeable to monomers of carbohydrates, fats and proteins.

163. Phloem in gymnosperms lacks :

- (1) Sieve tubes only
- (2) Companion cells only
- (3) Both sieve tubes and companion cells
- (4) Albuminous cells and sieve cells

164. Which of the following statements is **correct** ?

- (1) Cornea consists of dense connective tissue of elastin and can repair itself.
- (2) Cornea is convex, transparent layer which is highly vascularised.
- (3) Cornea consists of dense matrix of collagen and is the most sensitive portion of the eye.
- (4) Cornea is an external, transparent and protective proteinaceous covering of the eye-ball.

165. Which part of the brain is responsible for thermoregulation ?

- (1) Hypothalamus
- (2) Corpus callosum
- (3) Medulla oblongata
- (4) Cerebrum

166. In a species, the weight of newborn ranges from 2 to 5 kg. 97% of the newborn with an average weight between 3 to 3.3 kg survive whereas 99% of the infants born with weights from 2 to 2.5 kg or 4.5 to 5 kg die. Which type of selection process is taking place ?

- (1) Stabilizing Selection
- (2) Disruptive Selection
- (3) Cyclical Selection
- (4) Directional Selection

167. Which of the following is the most important cause for animals and plants being driven to extinction ?

- (1) Drought and floods
- (2) Economic exploitation
- (3) Alien species invasion
- (4) Habitat loss and fragmentation

168. Which one of the following equipments is essentially required for growing microbes on a large scale, for industrial production of enzymes ?

- (1) Sludge digester
- (2) Industrial oven
- (3) Bioreactor
- (4) BOD incubator

169. Xylem translocates :

- (1) Water and mineral salts only
- (2) Water, mineral salts and some organic nitrogen only
- (3) Water, mineral salts, some organic nitrogen and hormones
- (4) Water only

170. What map unit (Centimorgan) is adopted in the construction of genetic maps ?

- (1) A unit of distance between two expressed genes, representing 100% cross over.
- (2) A unit of distance between genes on chromosomes, representing 1% cross over.
- (3) A unit of distance between genes on chromosomes, representing 50% cross over.
- (4) A unit of distance between two expressed genes, representing 10% cross over.

171. Identify the cells whose secretion protects the lining of gastro-intestinal tract from various enzymes.
- (1) Goblet Cells
 - (2) Oxyntic Cells
 - (3) Duodenal Cells
 - (4) Chief Cells
172. In some plants, the female gamete develops into embryo without fertilization. This phenomenon is known as :
- (1) Parthenocarpy
 - (2) Syngamy
 - (3) Parthenogenesis
 - (4) Autogamy
173. Which of the following can be used as a biocontrol agent in the treatment of plant disease ?
- (1) *Chlorella*
 - (2) *Anabaena*
 - (3) *Lactobacillus*
 - (4) *Trichoderma*
174. Match Column - I with Column - II.
- | Column - I | Column - II |
|----------------|---|
| (a) Saprophyte | (i) Symbiotic association of fungi with plant roots |
| (b) Parasite | (ii) Decomposition of dead organic materials |
| (c) Lichens | (iii) Living on living plants or animals |
| (d) Mycorrhiza | (iv) Symbiotic association of algae and fungi |
- Choose the correct answer from the options given below :
- | | (a) | (b) | (c) | (d) |
|-----|-------|-------|-------|------|
| (1) | (iii) | (ii) | (i) | (iv) |
| (2) | (ii) | (i) | (iii) | (iv) |
| (3) | (ii) | (iii) | (iv) | (i) |
| (4) | (i) | (ii) | (iii) | (iv) |
175. Concanavalin A is :
- (1) an essential oil
 - (2) a lectin
 - (3) a pigment
 - (4) an alkaloid
176. Drug called 'Heroin' is synthesized by :
- (1) acetylation of morphine
 - (2) glycosylation of morphine
 - (3) nitration of morphine
 - (4) methylation of morphine
177. The ciliated epithelial cells are required to move particles or mucus in a specific direction. In humans, these cells are mainly present in :
- (1) Fallopian tubes and Pancreatic duct
 - (2) Eustachian tube and Salivary duct
 - (3) Bronchioles and Fallopian tubes
 - (4) Bile duct and Bronchioles
178. Which of the following muscular disorders is inherited ?
- (1) Muscular dystrophy
 - (2) Myasthenia gravis
 - (3) Botulism
 - (4) Tetany
179. Which one of the following statements regarding post-fertilization development in flowering plants is **incorrect** ?
- (1) Zygote develops into embryo
 - (2) Central cell develops into endosperm
 - (3) Ovules develop into embryo sac
 - (4) Ovary develops into fruit
180. Which of the following pair of organelles **does not** contain DNA ?
- (1) Chloroplast and Vacuoles
 - (2) Lysosomes and Vacuoles
 - (3) Nuclear envelope and Mitochondria
 - (4) Mitochondria and Lysosomes

- o o o -